

EcoStruxure™ EV Charging Expert Installation Guide



MFR6297701-11

Load Management System for electric vehicle charging

Safety Information



Important Information

Notice

Read these instructions carefully and look at the equipment to become familiar with the device before trying to install, operate, service, or maintain it. The following special messages may appear throughout this documentation or on the equipment to warn of potential hazards or to call attention to information that clarifies or simplifies a procedure.



This is the safety alert symbol. It is used to alert you to potential personal injury hazards. Obey all safety messages that follow this symbol to avoid possible injury or death.



The addition of this symbol to a "Danger" or "Warning" safety label indicates that an electrical hazard exists which will result in personal injury if the instructions are not followed.

DANGER

DANGER indicates a hazardous situation which, if not avoided, **will result in death or serious injury**.

WARNING

WARNING indicates a hazardous situation which, if not avoided, **could result in death or serious injury**.

CAUTION

CAUTION indicates a hazardous situation which, if not avoided, **could result in minor or moderate injury**.

NOTICE

NOTICE is used to address practices not related to physical injury.

Please note

Electrical equipment should be installed, operated, serviced, and maintained only by qualified personnel. No responsibility is assumed by Schneider Electric for any consequences arising out of the use of this material. A qualified person is one who has skills and knowledge related to the construction and operation of electrical equipment and its installation and has received safety training to recognize and avoid the hazards involved.

DANGER

HAZARD OF ELECTRIC SHOCK

- Do not open the product
- Product to be serviced by qualified people only

Failure to follow these instructions will result in death or serious injury.

WARNING

UNAUTHENTICATED ACCESS AND SUBSEQUENT UNAUTHORIZED MACHINE OPERATION

- Evaluate whether your environment or your machines are connected to your critical infrastructure and, if so, take appropriate steps in terms of prevention, based on Defense-in-Depth, before connecting the automation system to any network.
- Limit the number of devices connected to a network to the minimum necessary.
- Isolate your industrial network from other networks inside your company.
- Protect any network against unintended access by using firewalls, VPN, or other, proven security measures.
- Monitor activities within your systems.
- Prevent subject devices from direct access or direct link by unauthorized parties or unauthenticated actions.
- Prepare a recovery plan including backup of your system and process information.

Failure to follow these instructions could result in death or serious injury.

Customer Care Center



NOTE: All instructions applicable to the enclosed product and all safety precautions must be observed.

Chapter 1

Physical Overview

1.1 Preparation

1.1.1 Prerequisites

Information needed to prepare EcoStruxure EV Charging Expert commissioning:

- Phases rotation for each one of the charging stations to be managed
- Name for each of the charging stations to be managed
- Name of the different parking zone where the charging stations are located
- Parameters to install a remote supervision (ID CS, supervision URL)
- Single line power diagram with details of maximum current limits
- Strategy of authentication (badges, VIP, remote authentication)

Information needed regarding IT network:

- Network architecture
- Management of IP address
 - o Fixed IP (Obtain the IP addresses) / automatic IP (DHCP, Dynamic Host Configuration Protocol)

Necessary skills:

- Configure an IP address on the laptop
- Install a power meter
- Through the webserver of the charging stations
 - o Modify parameters
 - o Check the firmware and hardware
- Establish a phase balancing on the electrical network (3 phases and single phase EV chargers)

1.1.2 Package Contents

The following items are included in the package of the EcoStruxure EV Charging Expert . Before using the EcoStruxure EV Charging Expert, confirm that all items listed here are present:

EcoStruxure
EV Charging Expert

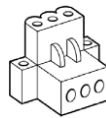
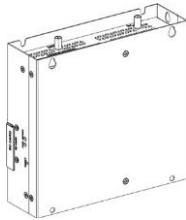

1 x DC terminal connector:
3-pin power connector



4 x screws and 4 x washers

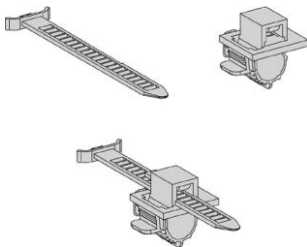

2 X FlexibleHDMI/USB lockers

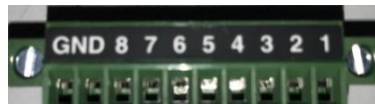

1 x GPIO terminal block



1 x wire for chassis ground

The EcoStruxure EV Charging Expert has been carefully packed, with special attention to quality. However, should you find anything damaged or missing, please request your local SE contact immediately.

1.1.3 Not included

- Power supply for the EcoStruxure EV Charging Expert
- Ethernet cable
- Din-Rail adaptor
- Laptop (go to the " 3.3.3 connection to the webserver" paragraph)

1.1.4 Before going on the customer site

You should:

- Download the user guide (reference DOCA0358EN) from our website at <https://www.se.com/fr/fr/product-range/62159-ecostruxure-ev-charging-expert/#documents>



- Download the most recent latest version of the EcoStruxure EV Charging Expert firmware from our website at <https://www.se.com/fr/fr/product-range/62159-ecostruxure-ev-charging-expert/#software-and-firmware>



1.2 Power Supply Characteristics

1.2.1 EcoStruxure EV Charging Expert Power Supply

Element	Characteristics
Rated voltage	24 Vdc (12...24 Vdc)
Inrush current	1,5 A
Power consumption	16 W

Chapter 2

Installation

2.1 Environmental Characteristics

2.1.1 Spacing Requirements

In order to provide sufficient air circulation, mount the EcoStruxure EV Charging Expert so that the spacing on the top, bottom, and side is as follows:

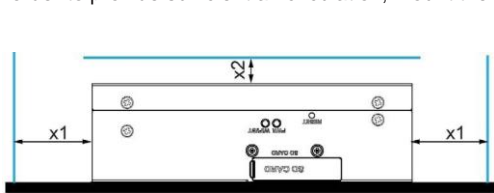

$x1 > 100 \text{ mm (3.93 in)}$
 $x2 > 50 \text{ mm (1.96 in)}$

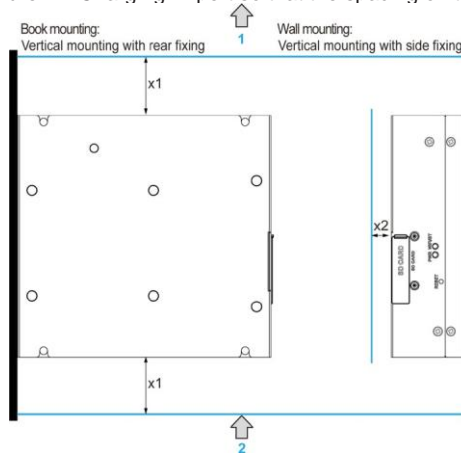

1. Air out
2. Air in
 $x1 > 100 \text{ mm (3.93 in)}$
 $x2 > 50 \text{ mm (1.96 in)}$

2.2 Installation of the EcoStruxure EV Charging Expert

Follow these steps for installation:

Step	Action
1	Remove the power and confirm that the power supply is disconnected from its power source.
2	<p>Wall mounting: Fasten the EcoStruxure EV Charging Expert on the cabinet with four M4 hex screws (8 mm (0.31 in)). Book mounting: Fasten the EcoStruxure EV Charging Expert on the cabinet with two M4 hex screws (8 mm (0.31 in)).</p> <div style="display: flex; justify-content: space-around;"> <div style="text-align: center;"> <p>Book mounting</p> </div> <div style="text-align: center;"> <p>Wall mounting</p> </div> </div> <p>NOTE: The recommended torque to tighten these screws is 0.5 Nm (4.5 lb-in). Horizontal mounting: Fasten the EcoStruxure EV Charging Expert with four M4 hex screws (8 mm (0.31 in)):</p> <div style="display: flex; justify-content: space-around;"> <div style="text-align: center;"> </div> <div style="text-align: center;"> </div> </div> <p>NOTE :</p> <ul style="list-style-type: none"> • The horizontal mounting is allowed with a temperature derating. See Environmental Characteristics (see EcoStruxure EV Charging Expert datasheet / User Guide DOCA0358EN). • For correct heat dissipation when horizontal mounting, the marking is at the bottom. • Use screwdriver less than 4.5 mm for Hex socket cap screws provided. • The recommended torque to tighten these screws is 0.5 Nm (4.5 lb-in).

2.3 Installation Din-Rail Mounting of the EcoStruxure EV Charging Expert (not supplied)

Follow these steps for installation:

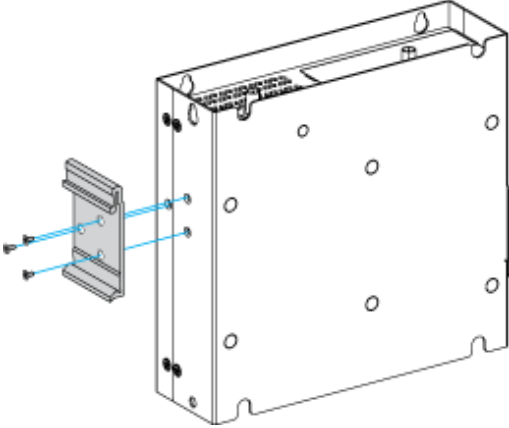
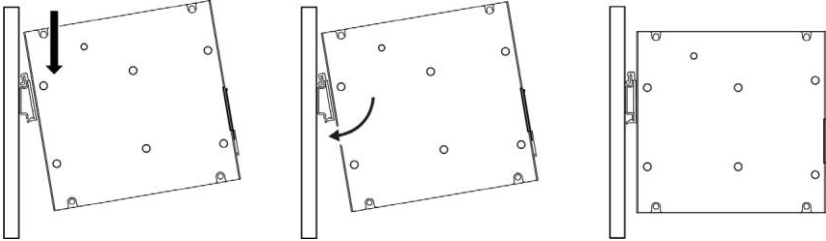
Step	Action
1	Remove the power and confirm that the power supply is disconnected from its power source.
2	Fasten the Din-rail bracket (HMIYADBMODIN11, not supplied) to the EcoStruxure EV Charging Expert with three M3 screws (6 mm (0.23 in)): 
3	Hook the EcoStruxure EV Charging Expert with bracket on the mounting rail: 

Chapter 3

Connections

3.1 Grounding

3.1.1 Overview

The grounding resistance between the EcoStruxure EV Charging Expert ground wire and the ground must be 100 Ω or less. When using a long grounding wire, check the resistance and, if required, replace the wire with a thicker wire and place it in a duct.

3.2 Grounding Procedure

 WARNING
RISK OF MATERIAL DAMAGE AND HOT ENCLOSURE
<ul style="list-style-type: none"> • Allow the product sufficient time to cool before touching • Follow proper mounting instructions including torque values and the crimping lengths on wire terminations. • Do not allow liquids or foreign objects to enter this product.
Failure to follow these instructions could result in death, serious injury, or equipment damage.

The EcoStruxure EV Charging Expert's ground has 2 connections:

- DC Supply voltage
- Ground connection pin

- 1 Ground connection pin (functional ground connection pin)
- 2 Switching cabinet
- 3 Grounding strip

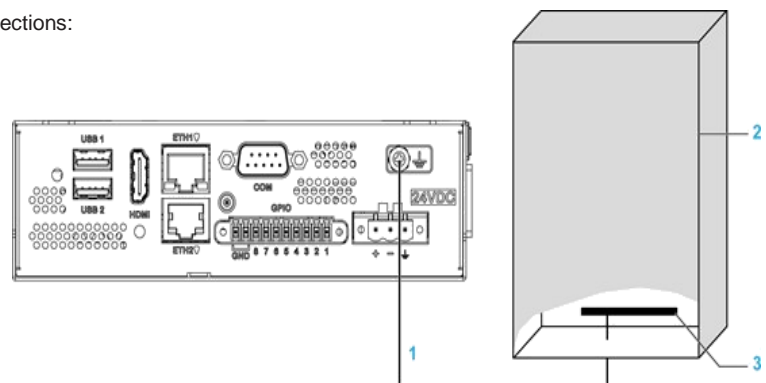

When grounding, follow this procedure:

Steps	Action
1	Ensure all the following actions are finished for the system wiring: <ul style="list-style-type: none"> • Connect the cabinet to ground. • Ensure that all cabinets are grounded together. • Connect the ground of the power supply to the cabinet. • Connect the ground pin of the EcoStruxure EV Charging Expert to the cabinet. • Connect the power supply to the EcoStruxure EV Charging Expert
2	Check that the grounding resistance is 100 Ω or less.
3	When connecting the functional ground to another device, ensure that the design of the system/connection does not produce a ground loop. NOTE: The functional ground and ground connection screw are connected internally in the EcoStruxure EV Charging Expert.
4	Use the wire for chassis ground provided in the EcoStruxure EV Charging Expert to make the ground connection. Create the connection point as close to the EcoStruxure EV Charging Expert as possible, Use 1.3 mm ² (AWG 16) Minimum.

3.3 Connecting the DC Power Cord

3.3.1 Precaution

When connecting the power cord to the power connector on the EcoStruxure EV Charging Expert, first ensure that the power cord is disconnected from the DC power supply.

⚠️ ⚠️ DANGER

HAZARD OF ELECTRIC SHOCK, EXPLOSION OR ARC FLASH
 Remove all power from the device before removing any covers or elements of the system, and prior to installing or removing any accessories, hardware, or cables.
 Unplug the power cable from both the EcoStruxure EV Charging Expert and the power supply.
 Always use a properly rated voltage sensing device to confirm power is off.
 Replace and secure all covers or elements of the system before applying power to the unit.
 Use only the specified voltage when operating the EcoStruxure EV Charging Expert. The DC unit is designed to use 24 Vdc input.
Failure to follow these instructions will result in death or serious injury.

⚠️ WARNING

EQUIPMENT DISCONNECTION OR UNINTENDED EQUIPMENT OPERATION
 Ensure that power, communication, and accessory connections do not place excessive stress on the ports. Consider the vibration in the environment.
 Securely attach power, communication, and external accessory cables to the panel or cabinet.
 Use only D-Sub 9-pin connector cables with a locking system in good condition.
 Use only commercially available USB cables.
Failure to follow the Schneider instructions could result in death, serious injury, or equipment damage.

3.3.2 Wiring and Connecting the Terminal Block of the EcoStruxure EV Charging Expert

The table below describes how to connect the power cord to the DC terminal block:

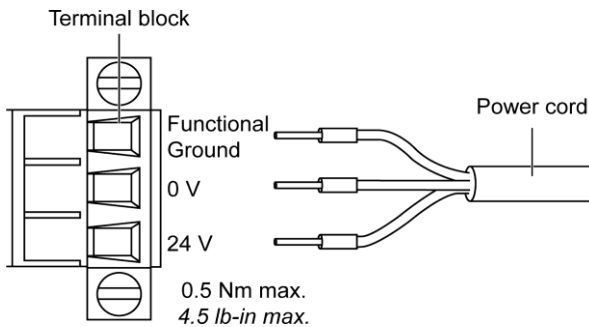
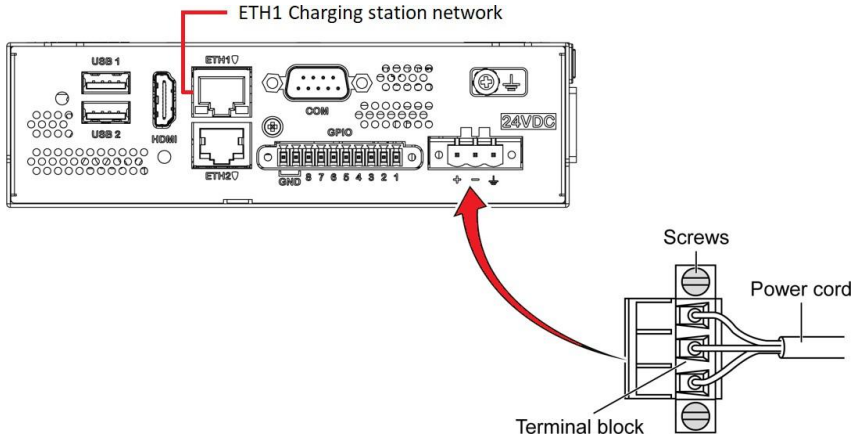
Steps	Action
1	Remove all power from the EcoStruxure EV Charging Expert and confirm that the DC power supply is disconnected from its power source.
2	<p>Remove the terminal block from the power connector on the EcoStruxure EV Charging Expert and connect the power cord to the terminal block.</p> <p>Use copper wire rated for 75 °C (167 °F) with a section of 0.75 to 2.5 mm² (AWG 18 to AWG 14) and use 2.5 mm² wire to make the ground connection.</p> <p>When connecting the functional ground to another device, ensure that the design of the system/connection does not produce a ground loop.</p> <div style="text-align: center;">  </div> <p>NOTE: The functional ground and ground connection screw are connected internally in the LM</p>
3	<p>a) Connect the EcoStruxure EV Charging Expert on the charging station network through ETH1</p> <p>b) Place the terminal block in the power connector and tighten the screws:</p> <div style="text-align: center;">  </div> <p>NOTE: The recommended torque to tighten these screws is 0.5 Nm (4.5 lb-in).</p>

Chapter 4

Operation

4.1 Connection to the webserver

The minimum requirements for using the commissioning tool are a computer supporting:

- an Ethernet port,
- an operating system including web browser Google Chrome version 72.0.3626.121 or above.
- a category 5e or above Ethernet cable.

First connection:

Steps	Action
1	Check that your computer is physically connected to EcoStruxure EV Charging Expert ETH1 Ethernet port
2	Open the local network properties menu of your computer.
3	Open Internet Protocol TCP/IP v4 properties.
4	Set the static IP address properties as follows: <ul style="list-style-type: none">• IP address: 192.168.0.x (where x is a number between 241 and 249) Subnet• Mask: 255.255.255.0• No default gateway• No DNS server• No proxy
5	Connect to the webserver on the address 192.168.0.128 and follow the onboarding If the EcoStruxure EV Charging Expert IP has been changed, you may not know its IP address. To have access to the product, you can use your computer to detect the EcoStruxure EV Charging Expert on the network. On Windows, open the Windows Explorer and click the network icon (scroll down on the left menu). After a short loading time, the EcoStruxure EV Charging Expert available on the network are displayed, named according to their reference. You can double-click on the EcoStruxure EV Charging Expert Icon to open its commissioning tool.

4.2 Back to factory settings

If you find yourself in a situation where you can no longer access your EcoStruxure EV Charging Expert user interface (for example, because you have lost your Admin credentials, or if you change the network settings in a wrong way) you may consider bringing your EcoStruxure EV Charging Expert back to its factory settings using the physical procedure to do it.

Refer to DOCA0358EN (EcoStruxure EV Charging Expert User guide), available on se.com/download.

 Schneider Electric Limited Stafford
Park 5
Telford TF3 3BL
United Kingdom