

# Zelio Control

## REG24 Temperature Controller User Guide

09/2012

E10000001300.00

[www.schneider-electric.com](http://www.schneider-electric.com)



---

Schneider Electric assumes no responsibility for any errors that may appear in this document. If you have any suggestions for improvements or amendments or have found errors in this publication, please notify us.

No part of this document may be reproduced in any form or by any means, electronic or mechanical, including photocopying, without express written permission of Schneider Electric.

All pertinent state, regional, and local safety regulations must be observed when installing and using this product. For reasons of safety and to help ensure compliance with documented system data, only the manufacturer should perform repairs to components.

When devices are used for applications with technical safety requirements, the relevant instructions must be followed.

Failure to use Schneider Electric software or approved software with our hardware products may result in injury, harm, or improper operating results.

Failure to observe this information can result in injury or equipment damage.

© 2012 Schneider Electric. All rights reserved.

---

# Table of Contents



---

	<b>Safety Information</b> .....	<b>5</b>
	<b>About the Book</b> .....	<b>7</b>
<b>Part I</b>	<b>REG24 Temperature Controller</b> .....	<b>9</b>
<b>Chapter 1</b>	<b>Introduction</b> .....	<b>11</b>
	Display and Controller References of REG24 .....	12
	Main Characteristics .....	15
<b>Chapter 2</b>	<b>Hardware of REG24</b> .....	<b>17</b>
	Electrical and Environmental Characteristics .....	18
	Dimensions and Installation of REG24 .....	20
	Wiring of REG24 .....	27
<b>Chapter 3</b>	<b>Configuration of REG24</b> .....	<b>31</b>
	How to Configure Using Front panel .....	32
	Basic Operations .....	33
	Key Lock .....	35
	Setting the Temperature Controller .....	37
	Parameters List .....	41
<b>Chapter 4</b>	<b>Main Functions of REG24</b> .....	<b>47</b>
	ON/OFF Control .....	48
	Auto-tuning .....	50
	Self-Tuning .....	53
	Alarm Function .....	55
	Ramp/Soak .....	63
	Other Function: Anti-reset windup (Ar) and Output Convergence Value (bAL) .....	67
<b>Part II</b>	<b>Appendices</b> .....	<b>69</b>
<b>Chapter 5</b>	<b>REG24 Error Message</b> .....	<b>71</b>
	Error Indications .....	71
<b>Index</b>	.....	<b>73</b>



---

## Safety Information

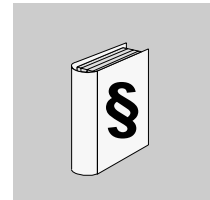

---

### Important Information

#### NOTICE

Read these instructions carefully, and look at the equipment to become familiar with the device before trying to install, operate, or maintain it. The following special messages may appear throughout this documentation or on the equipment to warn of potential hazards or to call attention to information that clarifies or simplifies a procedure.



The addition of this symbol to a Danger safety label indicates that an electrical hazard exists, which will result in personal injury if the instructions are not followed.



This is the safety alert symbol. It is used to alert you to potential personal injury hazards. Obey all safety messages that follow this symbol to avoid possible injury or death.

### **DANGER**

**DANGER** indicates an imminently hazardous situation which, if not avoided, **will result in** death or serious injury.

### **WARNING**

**WARNING** indicates a potentially hazardous situation which, if not avoided, **can result in** death or serious injury.

---

 **CAUTION**

**CAUTION** indicates a potentially hazardous situation which, if not avoided, **can result in** minor or moderate injury.

***NOTICE***

***NOTICE*** is used to address practices not related to physical injury.

**PLEASE NOTE**

Electrical equipment should be installed, operated, serviced, and maintained only by qualified personnel. No responsibility is assumed by Schneider Electric for any consequences arising out of the use of this material.

A qualified person is one who has skills and knowledge related to the construction and operation of electrical equipment and its installation, and has received safety training to recognize and avoid the hazards involved.

---

## About the Book

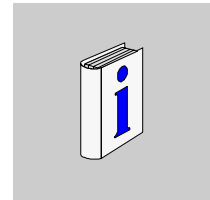

---

### At a Glance

#### Document Scope

This manual will acquaint you with the Temperature Controller REG24 tell you how to install them, describe changes you may make in configuration, review the operation.

The Temperature Controller is Single loop controller controlled devices performing the following enhanced functions:

- PID
- Auto-tuning
- Fuzzy logic
- Alarms
- Ramps

There are 3 versions of Temperature Controllers, with different sizes and characteristics.

The product references in accordance with the sizes are:

- REG24P•••••: 24x48 mm (0.94x1.89 in.)
- REG48P•••••: 48x48 mm (1.89x1.89 in.) (Refer to Zelio Control, REG48/96 Temperature Controller User Guide (*see Zelio Control, REG48/96 Temperature Controller, User Guide*))
- REG96P•••••: 48x96 mm (1.89x3.78 in.) Refer to Zelio Control, REG48/96 Temperature Controller User Guide (*see Zelio Control, REG48/96 Temperature Controller, User Guide*))

Solution approach used:

- Controllers
- Sensors
- Solid state and electromechanical relays

---

## Validity Note

This document is valid for Temperature Controllers REG24

### Registered Trademarks

Microsoft® and Windows® are registered trademarks of Microsoft Corporation.

## Related Documents

Title of Documentation	Reference Number
TSX CUSB485 USB to RS485 converter Quick Reference Guide	35013735
Zelio Control, REG48/96 Temperature Controller User Guide	EIO0000001299 (Eng), EIO0000001302 (Fre), EIO0000001305 (Ger), EIO0000001331 (Ita) EIO0000001334 (Spa) EIO0000001337 (Chs)
Zelio Control, REG Communication and ZelioControl Soft Installation User Guide	EIO0000001301 (Eng), EIO0000001304 (Fre), EIO0000001307 (Ger), EIO0000001333 (Ita), EIO0000001336 (Spa), EIO0000001339 (Chs)

You can download these technical publications and other technical information from our website at [www.schneider-electric.com](http://www.schneider-electric.com).

## User Comments

We welcome your comments about this document. You can reach us by e-mail at [techcomm@schneider-electric.com](mailto:techcomm@schneider-electric.com).

---

# REG24 Temperature Controller

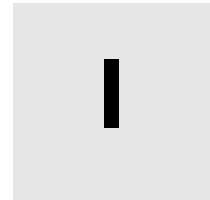

---

## What Is in This Part?

This part contains the following chapters:

Chapter	Chapter Name	Page
1	Introduction	11
2	Hardware of REG24	17
3	Configuration of REG24	31
4	Main Functions of REG24	47



---

# Introduction



# 1

---

## What Is in This Chapter?

This chapter contains the following topics:

<b>Topic</b>	<b>Page</b>
Display and Controller References of REG24	12
Main Characteristics	15

## Display and Controller References of REG24

### Overview

The REG24 is a smaller Temperature Controller (24 x 48 mm (0.94 x 1.89 in.)). It can be used in standalone installation for simple machine, or more complex in association with PLC (Programmable Logic Controller), HMI (Human Machine Interface) through communication Modbus (RS485).

The face panel has the Process Value (PV) and Setpoint Value (SV) displays, the status indicating lamp, and the setting keys.

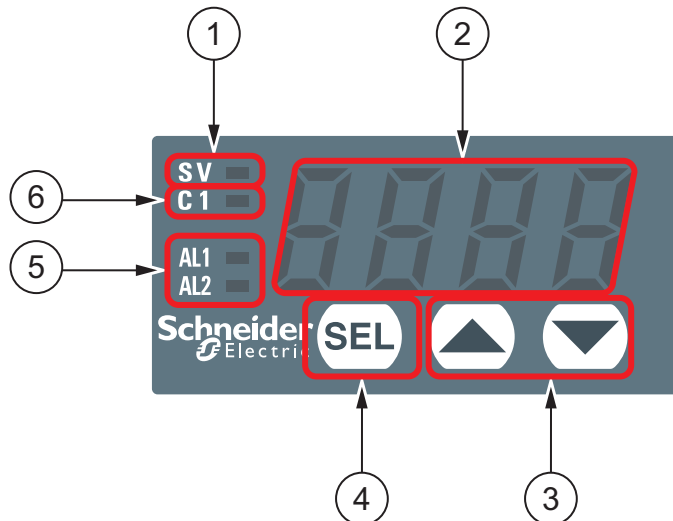

Item	Name	Function
1	Setpoint Value (SV) lamp	<ul style="list-style-type: none"> <li>The lamp is lit while a Setpoint Value (SV) is displayed.</li> <li>Flickers while the Process Value (PV) is displayed in Standby mode.</li> </ul>
2	Process Value (PV)/Setpoint Value (SV)/Parameter Name or Parameter Setting Display	<ul style="list-style-type: none"> <li>Displays a Process Value or Setpoint Value at operation mode.</li> <li>Displays the parameter name or settings at parameter setting mode.</li> <li>Displays the various detected error indications.</li> <li>Flickers at Standby mode when SV is displayed.</li> <li>Displays the Setpoint Value (SV) and "SV-x" (x:1 to 4) alternately when the SV-switching function is used and SV is displayed.</li> </ul>

Item	Name	Function
3	Down key / Up key	<ul style="list-style-type: none"> <li>Pressing once will decrease/increase the SV by one.</li> <li>Holding down the button will continue to decrease/increase the value.</li> <li>Changes SV on the PV/SV display.</li> <li>Move between parameters within the 1st, 2nd and 3rd block.</li> </ul>
4	Select (SEL) key	<ul style="list-style-type: none"> <li>Press once to toggle SV display. Press again return to PV display.</li> <li>Use this key to shift between 1st, the 2nd or the 3rd block parameter.</li> <li>Use this key to switch among different parameters and data among the parameters.</li> </ul>
5	Alarm Output (AL1)	The lamps are lit when alarm output is activated.
6	(C1) Control output indication lamp	The lamp is lit while the control output is ON.

### Controller References and Characteristics

The following table shows the controller references with the characteristics of each:

Part Number	Power supply	Input	Output	Modbus	Alarm
REG24PTP1RHU	100...240 Vac	Thermocouple, PT100	Relay	X	0
REG24PTP1ARHU		Thermocouple, PT100	Relay	-	1
REG24PUJ1RHU		Voltage / Current	Relay	X	0
REG24PTP1LHU		Thermocouple, PT100	SSR	X	0
REG24PTP1ALHU		Thermocouple, PT100	SSR	-	0
REG24PUJ1LHU		Voltage / Current	SSR	X	1
REG24PTP1JHU		Thermocouple, PT100	4-20mA	X	0
REG24PTP1RLU	24 Vdc/Vac	Thermocouple, PT100	Relay	X	0
RE 24PUJ1RLU		Voltage / Current	Relay	X	0
REG24PTP1LLU		Thermocouple, PT100	SSR	X	0
REG24PUJ1LLU		Voltage / Current	SSR	X	0
REG24PTP1JLU		Thermocouple, PT100	4-20mA	X	0
REG 24PSOC	Din rail support				

**Modbus Communication Accessories**

The following table shows the accessories for modbus communication:

<b>Part Number</b>	<b>Description</b>
TSXCUSB485 or VW3A8118	USB to RS485 converter
TWDXCAFJ010	1 x RJ45 connector and 1 end with flying leads
PC software	ZelioControl Soft V1.6 ZelioControl Soft V2.1 (new version)
TWDXCAISO	Isolated RS485 T-junction box
TWDXCAT3RJ	T-junction box
LU9GC3	Modbus splitter box

## Main Characteristics

### Overview

The following table presents the main characteristics of the REG24:

Characteristics	Values
Digits display	4 (10 mm (0.39 in.))
Buttons	3 (Up, Down and Sel)
Front face	IP66 NEMA-4X
Functions	Control method: <ul style="list-style-type: none"> <li>● PID</li> <li>● Self-tuning</li> <li>● Fuzzy logic</li> <li>● Auto-tuning mode</li> </ul>
Ramp	8
Power supply	<ul style="list-style-type: none"> <li>● 100 Vac...240 Vac</li> <li>● 24 Vac/Vdc</li> </ul>
Input	<ul style="list-style-type: none"> <li>● Thermocouple (J, K, R, B, S, T, E, N, PLII)</li> <li>● PT100</li> <li>● Voltage (1-5 Vdc)</li> <li>● Current (4-20 mA)</li> </ul>
Sampling rate	500 ms
Communication	RS485 Modbus (Baud Rate: 9600 and 19200 bps)
Output	<ul style="list-style-type: none"> <li>● Electromechanical relay</li> <li>● Solid state relay</li> <li>● Analog output current</li> </ul>
Standards	<ul style="list-style-type: none"> <li>● CE mark</li> <li>● UL Recognized</li> <li>● CSA</li> <li>● Gost</li> </ul>
Hazardous Substances	RoHs
Degree of protection	IP 66/NEMA 4x
EEPROM writing	100 000 maximum operations
PC Software	ZelioControl Software V1.6 ZelioControl Software V2.1 (new version)



---

# Hardware of REG24



# 2

---

## What Is in This Chapter?

This chapter contains the following topics:

<b>Topic</b>	<b>Page</b>
Electrical and Environmental Characteristics	18
Dimensions and Installation of REG24	20
Wiring of REG24	27

## Electrical and Environmental Characteristics

### Electrical Characteristics of REG24

The following table presents the electrical characteristics:

Specifications	Values
Power Supply	<ul style="list-style-type: none"> <li>● 100 Vac (-15%)...240 Vac (+10%).</li> <li>● 24 Vac/Vdc (+/-10%).</li> <li>● 50 Hz/60 Hz.</li> </ul>
Allowable Voltage	85 Vac...264 Vac.
Power Consumption	<ul style="list-style-type: none"> <li>● ≤ 6 VA for 100 Vac.</li> <li>● ≤ 8 VA for 240 Vac, 24 Vac, and 24 Vdc.</li> </ul>
Control output	Relay contact output: SPST-NO contact, 220Vac/30Vdc 3A (resistive load). SSR/SSC drive output (voltage pulse output) <ul style="list-style-type: none"> <li>● ON: 15 Vdc (12...16 Vdc).</li> <li>● OFF: ≤ 0.5 Vdc.</li> <li>● Max Current: ≤ 20 mA DC.</li> <li>● Load resistance ≥ 600 Ω</li> </ul> Current Output <ul style="list-style-type: none"> <li>● 4...20mA DC</li> <li>● Acceptable load resistance: 100 Ω..500 Ω</li> </ul>
Alarm output	<ul style="list-style-type: none"> <li>● Relay contact (SPST-NO contact).</li> <li>● 220 Vac/30 Vdc: 1A (resistive load).</li> </ul>
Communication function (RS485 interface, 9600 and 19200)	<ul style="list-style-type: none"> <li>● Transmission method: Half-duplex bit serial asynchronous cycle.</li> <li>● Transmission rate: 9600 or 19200 bps.</li> <li>● Transmission protocol: In conformity to Modbus RTU.</li> <li>● Transmission distance: Max 500 m (Total length).</li> <li>● Connectable units: 31units.</li> </ul>

**NOTE:** Connect a 250 Ω resistor when using current input. Refer to the Wiring topic (*see page 28*) for more information.

## Environmental Characteristics

The following table presents the Environmental Characteristics of the REG24:

Characteristics	Values
Operating ambient temperature	<ul style="list-style-type: none"><li>● -10...50 °C (14...122 °F)</li><li>● -10...45 °C (14...112 °F): for mounting close together.</li></ul>
Operating ambient humidity	≤90% RH - no condensation
Storage temperature	-20...+60 °C (-4...140° F).
Installation category	II (conforming to IEC1010-1).
Pollution degree	2 (conforming to IEC1010-1).
Conforming to standard	EMC EN 61326-1 LVD EN 61010-1

## Dimensions and Installation of REG24

### Dimensions of Controller

The following figure show the external dimensions with the panel mounting adapter:

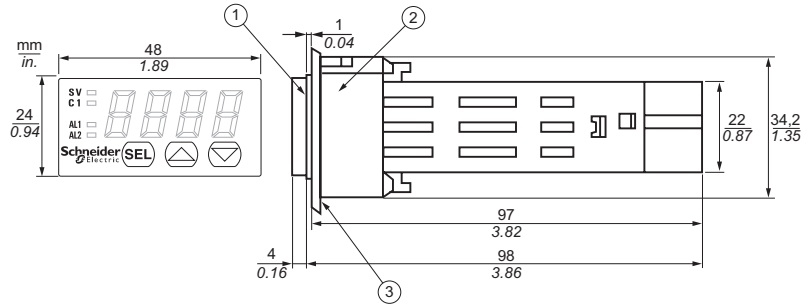

- 1 Front face
- 2 Panel mounting adapter
- 3 Panel

The following figure shows the external dimensions of the DIN-rail and the REG24PSOC DIN-rail mounting adapter:

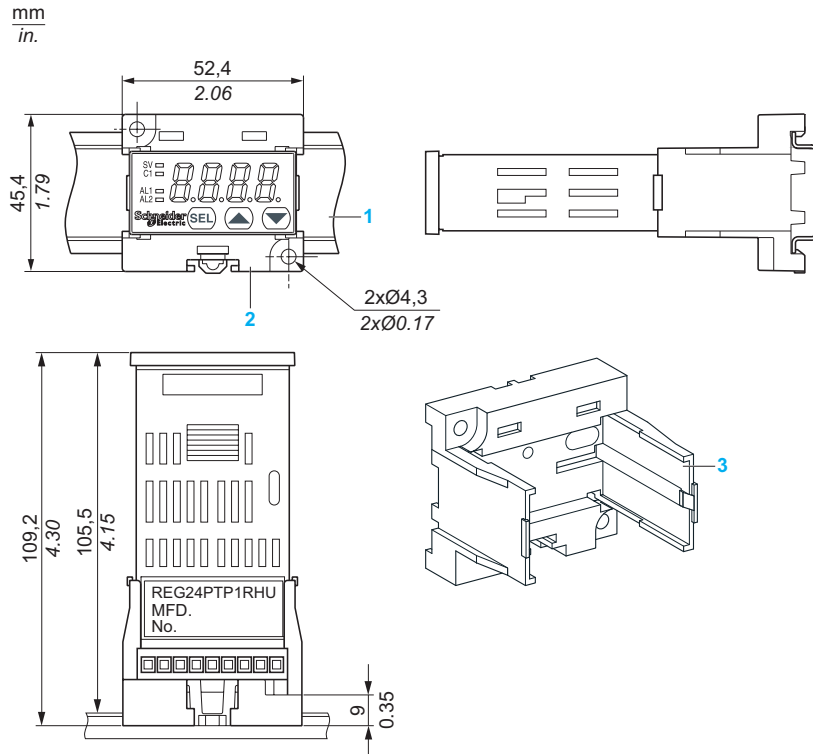

- 1 DIN rail  
2-3 REG24PSOC DIN-rail mounting adapter (optional)

The following figure shows how to mount the REG24 on the DIN-rail:

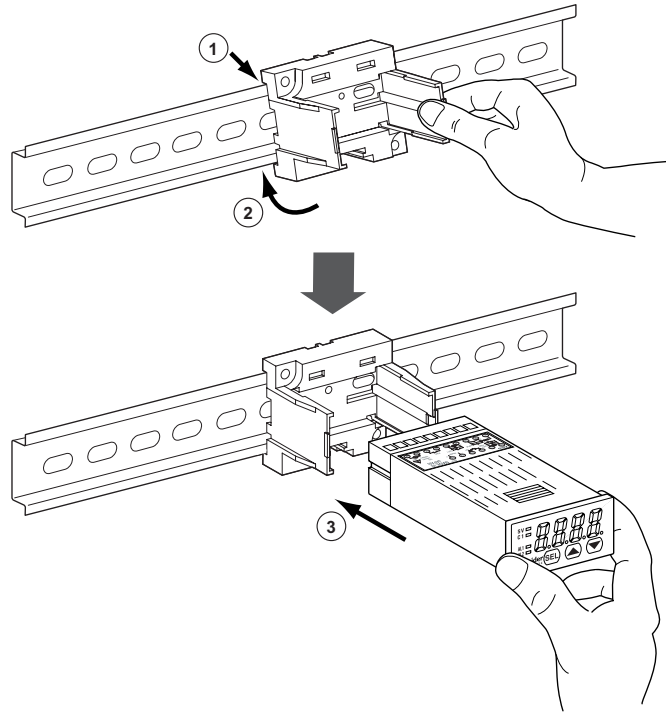

- 1 Hook the top side of the REG24PSOC.
- 2 Push in the bottom side.
- 3 Mount the REG24.

**NOTE:** Before mounting the REG24 connect the wire to the module

The following figure shows the dimension for mounting the REG24 on the wall:

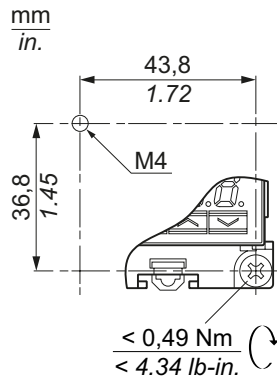

## Installation Precautions

### **WARNING**

#### **UNINTENDED EQUIPMENT OPERATION**

Do not install the controller where:

- Ambient temperature is outside the range of -10...50 °C (14...122° F) while in operation.
- Ambient humidity is more than 90% RH while in operation.
- Condensation can occur.
- Corrosive or combustible gases are present.
- There is vibration or shock higher than the specified value.
- Exposure to water oil, chemicals, steam or vapor.
- Exposure to dust, salty air, or air containing high concentrations of metal particles.
- Subject to electromagnetic interference from static electricity, magnetism, and external electromagnetic interference sources.
- Exposure to direct sunshine.
- Heat is accumulation due to solar radiation.

**Failure to follow these instructions can result in death, serious injury, or equipment damage.**

### **WARNING**

#### **UNINTENDED EQUIPMENT OPERATION**

Do not allow the openings around the controller to be blocked, or the unit's heat dissipation ability will be reduced.

Do not allow the ventilation openings on top of the terminal block to be blocked.

**Failure to follow these instructions can result in death, serious injury, or equipment damage.**

## NOTICE

### UNINTENDED EQUIPMENT OPERATINON

To ensure protection against dust and water (IP66):

- Use the appropriate panel cut out.
- Use the appropriate gasket and panel mounting adapter provided.
- Assemble the product according to installation guide.

**Failure to follow these instructions can result in equipment damage.**

**NOTE:** The front side of this controller conforms to NEMA 4X.

### Panel Cut-out

Panel cut-out dimensions for separate mounting:

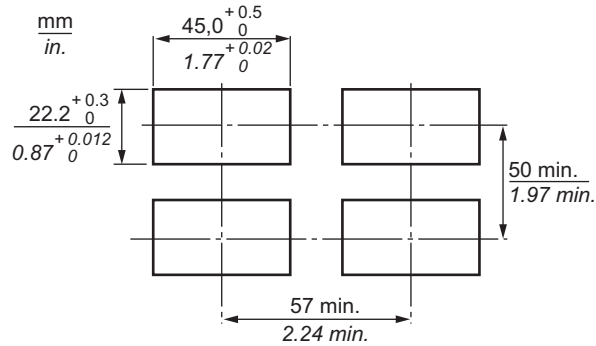

Panel cut-out dimensions for mounting close together:

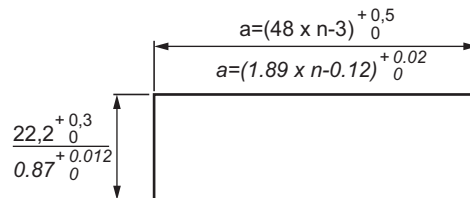

Value of a:

Number of units (n)	2	3	4	5	6
a (mm)	93	141	189	237	285
a (in.)	3.66	5.55	7.44	9.33	11.22

**NOTE:**

- The water resistance feature is unavailable if mounted close together.
- Maximum ambient temperature is 45° C (113° F) if mounted close together.

**Installation**

Follow the steps given below when installing the Controller:

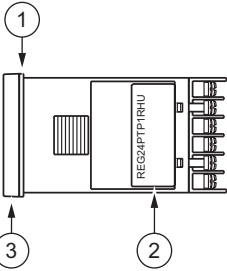
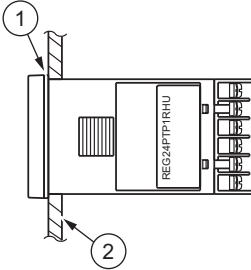
Step	Action
1	<p>Insert the IP66 protection gasket (include inside the packaging)(1) on the controller (3):</p>  <p><b>2</b> Label</p>
2	<p>Insert the controller (1) into the Panel Cut-out (2) with the label in up position:</p> 

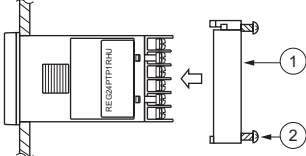
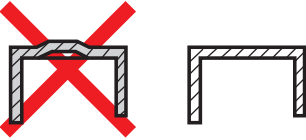
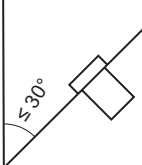
Step	Action
3	<p>Insert the panel mounting adapter (1) from rear of the controller and tighten the screws (2) to eliminate the gaps between the front of controller, gasket and panels</p> 
4	<p>If the front face is deformed like the left diagram, the panel cut out is insufficient:</p> 
5	<p>If you are installing the controller in a slanted panel, make sure that the panel is not tilted more than 30 degrees:</p> 

## Wiring of REG24

### Overview

# DANGER

## HAZARD OF ELECTRIC SHOCK, EXPLOSION OR ARC FLASH

- Remove all power from the controller.
- Always use a properly rated voltage sensing device to confirm power is off.
- Use only the specified voltage when operating the controller.

**Failure to follow these instructions will result in death or serious injury.**

### Wiring Installation Instructions

- For the thermocouple sensor type, use thermocouple compensation wires for wiring.
- For the RTD type, use a wiring material with a small lead wire resistance and no resistance differentials among three wires.
- Keep input lines away from power line and load line to avoid the influence from electromagnetic interference induced.
- For the input and output signal lines, be sure to use shielded wires and keep them properly segregated from each other.
- If an electromagnetic interference level is excessive in the power supply, the additional installation of an insulating transformer and the use of an electromagnetic interference filter are recommended.
- Use stranded power supply cable for the instrument.
- For the unit with an alarm against a burn-out in the heater, use the same power line for connection of the power supplies for the heater and the controller.
- A setup time is required for the contact output when the power is turned on. If the contact output is used as a signal for an external interlock circuit, use a delay relay at the same time.
- Use the auxiliary relay since the unit's operational life is shortened if full capacity load is connected to the output relay. Use the SSR/SSC drive output type if the output operations occur frequently.

- If an inductive load such as magnetic switches connected as a relay output load, use a protection module (Free wheel Diode or RC circuit or Varistor).
- Use a non-grounded sensor for resistance bulb or thermocouple of the SSR/SSC-driven output, output of 4...20 mA dc.

## ⚠ WARNING

### UNINTENDED EQUIPMENT OPERATION

Follow the wiring rules explained above in the Wiring Installation Instructions section.

**Failure to follow these instructions can result in death, serious injury, or equipment damage.**

### Wiring of the REG24

The following figure displays the wiring of the REG24 Controllers:

**REG24PTP1RHU, REG24PUJ1RHU,  
REG24PTP1LHU, REG24PUJ1LHU,  
REG24PTP1JHU**

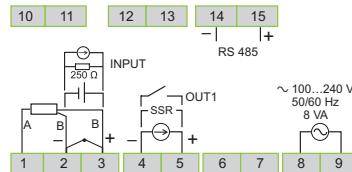

**REG24PTP1RLU, REG24PUJ1RLU,  
REG24PTP1LLU, REG24PUJ1LLU,  
REG24PTP1JLU,**

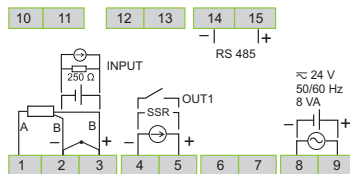

**REG24PTP1ARHU, REG24PTP1ALHU**

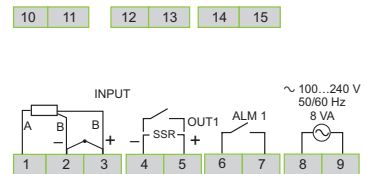

**Designation of Wiring Material****NOTE:**

- Do not use wire other than the one stated below.
- Be sure to insert wire toward the recess of the terminal block.
- The recommended torque is 0.4 N•m (3.54 lb-in).

**Wire:**

- (1): Gauge: AWG28 (0.1 mm<sup>2</sup>) to AWG16 (1.25 mm<sup>2</sup>).
- (2): Strip-off length: 5...6 mm (0.20...0.24 in.).

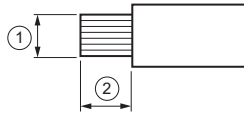
**Rod terminal:**

- (3) (4): Dimension of exposed conductor section: 2 x 1.5 mm (0.08 x 0.06 in.) or smaller.
- (5): Length of exposed conductor section: 5...6 mm (0.2...0.24 in.).

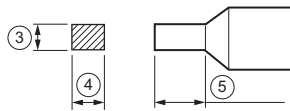



---

# Configuration of REG24

# 3

---

## What Is in This Chapter?

This chapter contains the following topics:

<b>Topic</b>	<b>Page</b>
How to Configure Using Front panel	32
Basic Operations	33
Key Lock	35
Setting the Temperature Controller	37
Parameters List	41

## How to Configure Using Front panel

### Overview

To configure the module you can use the Keys on the Panel or for more information refer to the Zelio Control, REG Communication and ZelioControl Soft Installation (see page 8).

**NOTE:** Some parameters are not displayed on the panel depending on different models or masking the parameters in purpose or depending on the selection of KeyLoc for modifiable parameters.

### Changing the Modes

Pressing the **(SEL)** key switches between mods. Pressing **(▲)** or **(▼)** allows you to choose menu items:

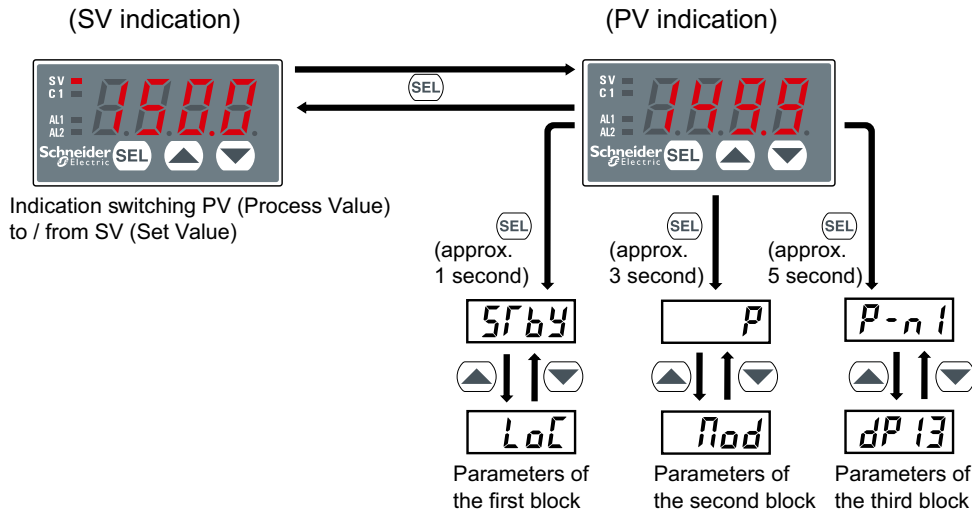

**NOTE:**

- Press the **(▲)** key to increase or the **(▼)** key to decrease the value by one.
- Press and hold the **(▲)** key to increase or the **(▼)** key to decrease the value.
- Pressing the **(SEL)** key:
  - for 2 seconds after setting parameters, the indication shifts to the SV indication state.
  - allows to switch PV to/from SV.
- If the device has not been operated for 30 seconds, the display returns to the PV indication state.

## Basic Operations

### Standby Mode

To perform standby operation, set Stby as ON in the first block parameter.

In Standby Mode, Control output (C1) and alarm output (AL1) are not provided. However, depending on setting of  $p-n$  (Control action), the control output is provided at the abnormal input. No alarm output is provided at Standby mode, even in (Fault-condition).

The following graphic presents how to perform standby operation:

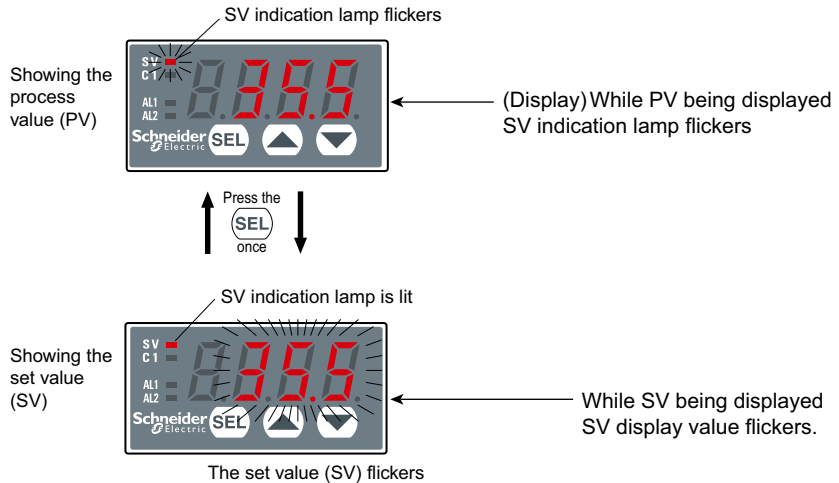

**NOTE:** The SV display does not flicker while the 1st, 2nd and 3rd block parameters are displayed.

### Parameter Setting Mode

The following graphic presents how to set the parameters for the device:

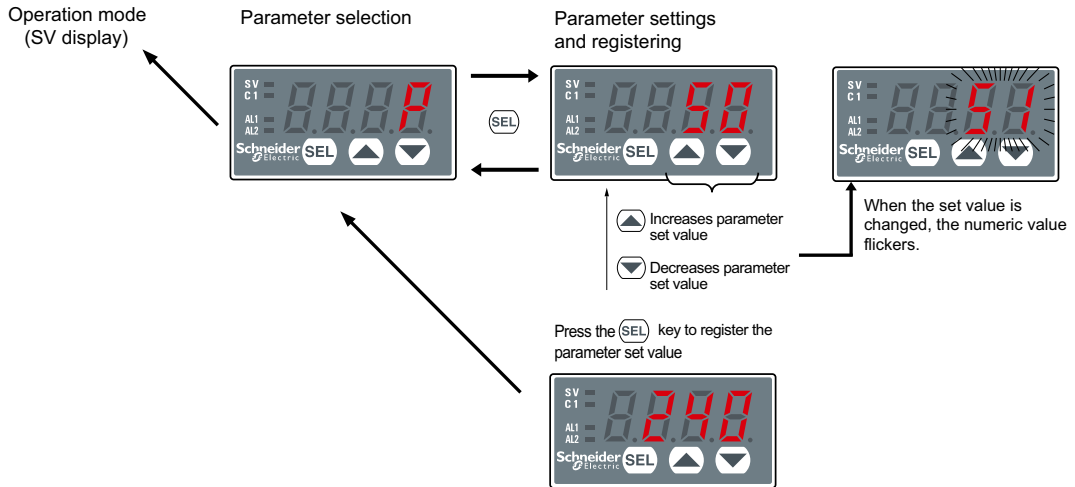

Step	Action
1	<b>Parameter selection</b> Press the (▲) and the (▼) key to select the parameter to set.
2	<b>Parameter settings and registering</b> Press once the (SEL) key to display and change the parameter set value (SV).  Use the (▲) and the (▼) key to increase/decrease the parameter set value. <b>Results:</b> the parameter value will blink.
3	<b>Parameter registering</b> Press one the (SEL) key to register the parameter set value.  <b>Results:</b> <ul style="list-style-type: none"> <li>• The parameter value will then cease to blink.</li> <li>• The device returns to the parameter selection mode</li> </ul>
4	<b>Operation mode</b> Press the (SEL) key for 2 seconds shift to Operation mode (SV display)

**NOTE:** If unoperated state continues for 30 seconds, the device returns to Operation/Standby mode.

## Key Lock

### Overview

The Key Lock parameter makes the set values of parameters unchangeable, but each set values can be displayed.

**NOTE:** Even when the Key Lock is set, Control and Alarm functions can operate properly.

The Key Lock parameter can be set:

- **0**8888 : Unlocked (reset the Key lock parameter)
- **1**8888 : All settings are unchangeable from the controller front panel, but can be modified via communication.
- **2**8888 : Only the SV is changeable from the controller front panel, and all settings can be modified via communication.
- **3**8888 : All settings are changeable from the controller front panel, but unchangeable via communication.
- **4**8888 : All settings are unchangeable from the controller front panel or via communication.
- **5**8888 : Only the SV is changeable from the controller front panel, but all settings are unchangeable via communication.



The following table resumes the setting of Key Lock parameter:

	All parameters		SV	
	Front key	Communication	Front key	Communication
<b>0</b> 8888	+	+	+	+
<b>1</b> 8888	-	+	-	+
<b>2</b> 8888	-	+	+	+
<b>3</b> 8888	+	-	+	-
<b>4</b> 8888	-	-	-	-
<b>5</b> 8888	-	-	+	-
+ Setting enable - Setting disable				

### Setting Key Lock

When key lock is activated, parameters cannot be changed but can displayed.

Use the following steps to set Key Lock:

Step	Action
1	Press and hold the <b>(SEL)</b> key for one second.
2	Press the  key to display key lock <b>L<sub>o</sub>L</b>
3	Press the <b>(SEL)</b> key once. The current setting will be displayed.
4	Press the  or  to Set the value.
5	Press the <b>(SEL)</b> key once. <b>L<sub>o</sub>L</b> will be displayed and the Set value will be registered. <b>NOTE:</b> Any setting other than the SV cannot be changed from the front panel

## Setting the Temperature Controller

### Setting of the Input Type

The input sensor type and the range for the input sensor can be set using  $P-nL$ :

Step	Action
1	Choose an input type ( $P-nL$ ) Check the type of the thermocouple or resistance bulb which is used. <b>NOTE:</b> The input type can be changed using $P-nL$ code within the same group only.
2	Set P-SL ( <i>see page 42</i> ) to the lower limit of the temperature range and P-SU ( <i>see page 42</i> ) to the upper limit. It is recommended to set the values at the standard range, even though they can be set at values beyond of it. There is no standard range for DC voltage or DC current input. (-1999 to 9999, lower limit<upper limit)
3	Set the decimal point location ( $P-dP$ ) Sets whether or not to display digits after the decimal point. Two digits can also be displayed after the decimal point when using 1 to 5Vdc, and 4 to 20mA dc.

**NOTE:** The decimal point location can be used with the default factory settings.

### Input Range and Codes Table

The following table provides more informations on input types, input scaling, decimal point location and input codes:

Group	Input type		Measurement range [° C]	Measurement range [° F]	Input code
I	Resistance bulb JIS (IEC)	Pt 100Ω	0 to 150	32 to 302	1.000
			0 to 300	32 to 572	
			0 to 500	32 to 932	
			0 to 600	32 to 1112	
			-50 to 100	-58 to 212	
			-100 to 200	-148 to 392	
			-150 to 600	-238 to 1112	
			-150 to 850	-228 to 1562	
	Thermocouple	J	0 to 400	32 to 752	2.000
			0 to 800	32 to 1472	
		K	0 to 400	32 to 752	3.000
			0 to 800	32 to 1472	
			0 to 1200	32 to 2192	
		R	0 to 1600	32 to 2912	4.000
		B	0 to 1800	32 to 3272	5.000
		S	0 to 1600	32 to 2912	6.000
		T	-199 to 200	-328 to 392	7.000
			-150 to 400	-238 to 752	
		E	0 to 800	32 to 1472	8.000
			-199 to 800	-328 to 1472	
N	0 to 1300	32 to 2372	12.000		
PL-2	0 to 1300	32 to 2372	13.000		
II	DC voltage	1 to 5 Vdc	-1999 to 9999 (Range where scaling is allowed)		1.600
	DC current <sup>1</sup>	4 to 20mA dc			1.600
<b>1</b> Connect a 250Ω resistor when using DC current input.					

## Setting of the Controls Output Action

- Reverse action
  - As the process value (PV) rises, the control output (MV) becomes smaller. Used to heat the control object.
  - As the process value (PV) becomes smaller, the control output (MV) rises. Used to heat the control object.
- Direct action:
  - As the process value (PV) rises, the control output (MV) becomes larger. Used to cool the control object.
  - As the process value (PV) decreases, the control output (MV) becomes smaller. Used to cool the control object.

The range of the control output can be set with  $\beta - n \uparrow$ :

Step	Action
1	Set the normal or direct action with $\beta - n \uparrow$ parameter.

Choose any of the following combinations of heat and cool to suit your system:

$\beta - n \uparrow$	Control output action	Output at Burn-out
0	Reverse	Lower limit
1		Upper limit
2	Direct	Lower limit
3		Upper limit

### Setting of the Control Algorithm

The control algorithm can be set depending of the type of control required:

Type of control	Description	Setting procedure
ON/OFF control	Output is either ON (100%) or OFF (0%). (Suitable when frequent output switching is inconvenient.)	Set $p = 0$ For more information, refer to ON/OFF Control function (see page 48).
PID Control	The output signal changes within the range from 0% to 100% according to PID calculation which determine the proportional of ON to OFF in each cycle time	Select $\overline{P\ I\ D}$ and choose $P\ I\ D$ . Each parameter can be set either by manually tuning the values or by running auto-tuning (AT) to automatically set the values. For more information, refer to Auto-tuning function (see page 50).
Fuzzy Control	Related to normal PID control, Fuzzy PID control acts with small overshoot	Select $\overline{F\ P\ I}$ and choose $F\ U\ Z\ Y$ . Then execute the Auto-tuning so that the Fuzzy Control function starts.
PID control with Self-tuning	Self-tuning Control is a control which automatically calculates the value of PID, under the condition that the control target or Setpoint value (SV) changes. Self-tuning is especially effective for situations when a high level of control is not needed, but auto-tuning cannot be run due to the frequent changes in the control target conditions.	Select $\overline{P\ I\ D}$ and choose $S\ E\ L\ F$ . For more information, refer to Self-tuning function (see page 53).

## Parameters List

### Overview

The parameters for the REG24 are classified under three sub-menus according to the frequency of use. The parameters of the second and third blocks are used at initialization or when they are of absolute necessity.

Some parameters may not be displayed at the time of delivery depending on the type of the Controllers.

### First Block Parameters

The following table presents the parameters used in the first block:

Display	Parameters name		Function	Setting Range	Factory Default Setting
STBY	STbY	Standby setting	Switches the operation mode between run and standby	<ul style="list-style-type: none"> <li>● oN: Control standby (Output: OFF, Alarm: OFF)</li> <li>● oFF: Control RUN</li> </ul>	oFF
ProG	ProG	Ramp/Soak Operation command	Switches between ramp/soak operation states	<ul style="list-style-type: none"> <li>● oFF: (stop/finish)</li> <li>● rUn: (run)</li> <li>● HLd: (hold)</li> </ul>	oFF
LACH	LACH	Alarm latch cancel	Cancels the DO output latch state	0: Keeps the alarm latch. 1: Opens up the alarm latch.	0
AT	AT	Auto-Tuning	Used for setting the constants for $P$ , $I$ and $d$ by Auto-tuning.	0: OFF (Resets the auto-tuning or does not use it) 1: ON (Performs the auto-tuning in the SV standard type.) 2: Low [Performs the auto-tuning in low type (SV value-10%FS).]	0
TM-1	TM-1	Timer 1 display	Displays the remaining time of timer 1.	- (Unit: seconds)	TM1

Display	Parameters name		Function	Setting Range	Factory Default Setting
$AL1$	AL1	Alarm 1 Set value	Sets the value at which alarm 1 is detected.	When the alarm type is absolute value: 0...100%FS. When the alarm type is deviation: -100...100%FS.	10
$A1-L$	A1-L	Alarm 1 low limit Set value	Sets the lower limit value at which alarm 1 is detected.		10
$A1-H$	A1-H	Alarm 1 high limit Set value	Sets the upper limit value at which alarm 1 is detected.		10
$LoC$	LoC	Key lock	Specifies whether or not to allow the change of parameters.	For more information about the Key Lock setting, refer to Key lock function (see page 35).	0

### Second Block Parameters

The following table presents the parameters used in the second block:

Display	Parameters name		Function	Setting Range	Factory Default Setting
$P$	P	Proportional band	Set $P$ to 0.0 to select the ON/OFF control (Two-position control).	0.0...999.9%	5.0
$I$	I	Integral time	No Integrate Action when $I = 0$	0...3200 seconds	240
$d$	D	Derivative time	No Derivative Action when $d = 0$	0.0...999.9 seconds	60.0
$HYS$	HYS	Hysteresis range for ON/OFF control	Sets the hysteresis for ON/OFF control.	0...50%FS	1
$Cool$	Cool	Cooling-side proportional band coefficient	Sets the cooling proportional band coefficient Setting "0.0" will turn the cooling into an on/off control	0.0...100.0	1.0
$db$	db	Deadband/Overlap	Shifts the set value for the cooling proportional band	-50.0...+50.0%	0.0
$bAL$	bAL	Output convergence value	Offset value for calculating the MV output value	-100...100%	0.0

Display	Parameters name		Function	Setting Range	Factory Default Setting
<i>Ar</i>	Ar	Anti-reset windup	Sets the range of Integration.	0...100%FS	100
<i>Ctrl</i>	CTrL	Control methods	Allows you to select the control method	PID: Runs normal PID control. FUZY: Runs PID control with fuzzy logic. SELF: Runs PID control with Self-tuning.	-
<i>SLFb</i>	SLFb	PV (Measured value) stable range	Sets the PV stable range for the self-tuning operation.	0...100%FS	8
<i>onoF</i>	onoF	Setting HYS (Hysteresis) mode	Selects the hysteresis operation at ON/OFF control.	oFF: Starts the two-position control at the values of SV+HYS/2 and SV-HYS/2. oN: Starts the two-position control at the values of SV and SV+HYS, or SV and SV HYS.	oFF
<i>OUT1</i>	TC	OUT1 cycle time	Sets the cycle time of the control output (OUT1) (Contact, SSR drive)	RLY, SSR: 1...150 seconds	30: SSR 2: Relay
<i>P-n2</i>	P-n2	Input signal code	Set this parameter when changing the types of temperature sensors. For more information, refer to the Input Range and Code Table (see page 38)	1 to 16	-
<i>P-SL</i>	P-SL	Lower limit of measuring range	For more information, refer to the Input Range and Code Table (see page 38)	-1999...9999	-
<i>P-SU</i>	P-SU	Upper limit of measuring range	For more information, refer to the Input Range and Code Table (see page 38)		-
<i>P-dP</i>	P-dP	Decimal position	Sets the position of the decimal point for PV/SV display	0 (no decimal point) 1 (one decimal place) 2 (two decimal places)	0
<i>P-F</i>	P-F	°C / °F selection	-	°C / °F	0
<i>PVOF</i>	PVOF	PV input offset	Sets the amount of offset for PV input	-100...100%FS	0
<i>SVOF</i>	SVOF	SV offset	Shift the SV. But the SV display is not changed.	-50...50%FS	0

Display	Parameters name		Function	Setting Range	Factory Default Setting
<i>P-dF</i>	P-dF	Time constant of input filter	Time constant	0.0...900.0 seconds	5.0
<i>ALM1</i>	ALM1	Alarm type 1	Sets the types of alarm operations.	0 to 31	0
<i>STAT</i>	STAT	Ramp/soak progress	Display the current Ramp/Soak status. <b>NOTE:</b> No setting can be made.	-	-
<i>PTn</i>	PTn	Ramp/Soak Activation Pattern	Sets which steps to execute in the Ramp/Soak operation pattern	1: Performs 1st to 4th segments. 2: Performs 5th to 8th segments. 3: Performs 1st to 8th segments.	1
<i>Sv-1</i> ... <i>Sv-8</i>	Sv-1 ... Sv-8	Ramp target SV-1 to SV-8	Sets the target SV for each ramp segment.	Within the SV limit.	0%FS
<i>TM1r</i> ... <i>TM8r</i>	TM1r ... TM8r	1st ramp segment time to 8th ramp segment time	Sets the 1st ramp segment time to the 8th ramp segment time.	0...99h59m	0.00
<i>TM1S</i> ... <i>TM8S</i>	TM1S ... TM8S	1st soak segment time to 8th soak segment time	Sets the 1st soak segment time to the 8th soak segment time.		0.00

### Third Block Parameters

The following table presents the parameters used in the third block:

Display	Parameter name		Function	Setting Range	Factory Default Setting
<i>P-n1</i>	P-n1	Control action	Specifies control action and output at the input burn-out. for more information, refer to Setting of the Controls Output Action ( <i>see page 39</i> ).	0 to 3	0
<i>Sv-L</i>	Sv-L	SVlimit (lower)	Sets the lower limit of the SV.	0...100%FS	100
<i>Sv-H</i>	Sv-H	SVlimit (upper)	Sets the upper limit of the SV.		100

Display	Parameter name		Function	Setting Range	Factory Default Setting																	
<i>dLY1</i>	dLY1	Delay time 1	Delay time or timer value for alarm output.	0...9999 seconds	0																	
<i>A1hy</i>	A1hy	Alarm 1 hysteresis	Sets the hysteresis range of ON and OFF of alarm 1.	0...50%FS	0																	
<i>A1oP</i>	A1oP	Alarm 1 options	Sets the optional functions of alarms 1:  (1): Alarm latch (1: use, 0: not use) (2): Alarm of error status (1: use; 0: not use) (3): De-energized output (1: use, 0: not use)	000 to 111	000																	
<i>PLC1</i>	PLC1	OUT1 lower limit	Sets the lower limit for output 1.	-3.0...103.0%	-3.0																	
<i>PHC1</i>	PHC1	OUT1 upper limit	Sets the upper limit for output 1.		103.0																	
<i>PCUT</i>	PCUT	Selects the output limiter type	Sets the limit types of outputs (breaking the limit, or maintained within the limit). <table border="1" style="margin-left: auto; margin-right: auto;"> <thead> <tr> <th rowspan="2">PCUT</th> <th colspan="2">Output</th> </tr> <tr> <th>Upper limit</th> <th>Lower limit</th> </tr> </thead> <tbody> <tr> <td>0</td> <td>103%</td> <td>-3%</td> </tr> <tr> <td>1</td> <td>103%</td> <td>Limit</td> </tr> <tr> <td>2</td> <td>Limit</td> <td>-3%</td> </tr> <tr> <td>3</td> <td>Limit</td> <td>Limit</td> </tr> </tbody> </table>	PCUT	Output		Upper limit	Lower limit	0	103%	-3%	1	103%	Limit	2	Limit	-3%	3	Limit	Limit	0 to 3	0
PCUT	Output																					
	Upper limit	Lower limit																				
0	103%	-3%																				
1	103%	Limit																				
2	Limit	-3%																				
3	Limit	Limit																				
<i>oUT1</i>	oUT1	Output value (MV) display	Displays the value of output 1.	For display purpose only. Cannot make the setting change.	-																	
<i>rCJ</i>	rCJ	Cold Junction Compensation	Sets whether cold junction compensation is performed	oN: Performs the RCJ (Cold junction compensation). oFF: Does not perform the RCJ (Cold junction compensation).	oN																	

Display	Parameter name		Function	Setting Range	Factory Default Setting
<i>Adj0</i>	Adj0	PV display Zero adjustment	Adjusts the zero side in the PV display	-50...50%FS	0
<i>Adj5</i>	AdjS	PV display Span adjustment	Adjusts the span side in the PV display		100
<i>STno</i>	STno	Station No.	Sets the station number. <b>NOTE:</b> Need to restart the controller once station No change.	0 to 255 (Setting to <i>ST</i> does not start the communications function.)	1
<i>Com</i>	CoM	Baud Rate/ Parity setting	Sets the baud rate and parity check	0: 96od (9600 bps / odd) 1: 96ev (9600 bps / even) 2: 96no (9600 bps / none) 3: 19od (19200 bps / odd) 4: 19ev (19200 bps / even) 5: 19no (19200 bps / none)	0
<i>dSP1</i> to <i>dSP9</i> <i>dP10</i> to <i>dP13</i>	dSP1 to dSP9 dSP10 to dSP13	Parameter mask	Sets whether or not to display each parameter.	0 to 255	-

---

# Main Functions of REG24



---

## What Is in This Chapter?

This chapter contains the following topics:

Topic	Page
ON/OFF Control	48
Auto-tuning	50
Self-Tuning	53
Alarm Function	55
Ramp/Soak	63
Other Function: Anti-reset windup (Ar) and Output Convergence Value (bAL)	67

## ON/OFF Control

### Overview

At ON/OFF Control mode, output signal is as shown below:

- Set parameter  $p = 0$  for selecting the ON/OFF control mode.
- Set the hysteresis to avoid chattering (Default setting:  $HYS=1$ ).
- When the hysteresis range (Range of ON/OFF Control) is too small, the output may switch from/to ON/OFF frequently. (This may affect the relay contact life.)

### How to Set the Hysteresis

The following table presents an example of changing the hysteresis from 1°C to 35°C:

Step	Action
1	Press and hold the <b>(SEL)</b> key for three second. $p$ parameter will be displayed.
2	Press the <b>(▼)</b> key and select $HYS$ .
3	Press the <b>(SEL)</b> key once to set the value.
4	Press <b>(▲)</b> and <b>(▼)</b> to flicker and to display 35.
5	Press the <b>(SEL)</b> key once. $HYS$ will be displayed and 35°C will be register for $HYS$ . After that the controller will operate with the $HYS$ being 35°C

**NOTE:** If you want to display the operation status, press and hold the **(SEL)** key for two seconds. The SV will be displayed on the display area.

**Parameter Setting and Operation Example:**

The following table present an example of Reverse operation:

Parameter	Setpoint value	Hysteresis
$p$	0.0	
$p-n1$	0 (or 1)	
$HYS$	Any value	
<b>Relationship of PV and SV</b>	<b>Output</b>	
$PV > SV$	ON	
$PV < SV$	OFF	(1): PV, when PV increases (2): PV, when PV decreases

The following table present an example of Direct operation:

Parameter	Setpoint value	Hysteresis
$p$	0.0	
$p-n1$	2 (or 3)	
$HYS$	Any value	
<b>Relationship of PV and SV</b>	<b>Output</b>	
$PV > SV$	OFF	
$PV < SV$	ON	(3): PV, when PV increases (4): PV, when PV decreases

## Auto-tuning

### Overview

Auto-tuning, located in the first block, is the automatic calculation and entering of the control parameters ( $P$ ,  $\tau$ , and  $d$ ) into memory. Prior to the Auto-tuning, complete the setting of input range ( $P-SL$ ,  $P-SH$ ,  $P-dP$ ), a Setpoint value (SV), alarm setting ( $AL$ ), and cycle time ( $CT$ ).

### Description

**NOTE:** If the controller is powered off during Auto-tuning, this makes the Auto-tuning ineffective with each parameter of  $P$ ,  $\tau$ , and  $d$  unchanged. To start the Auto-tuning set  $RT$  to "1" or "2" again.

- To suspend the Auto-tuning, set  $RT$  to "0". This makes the Auto-tuning cancel with each parameter of  $P$ ,  $\tau$ ,  $d$  and unchanged.
- Once the parameters of  $P$ ,  $\tau$ , and  $d$  are set automatically by the Auto-tuning, those parameters are stored in the controller even after it is powered off. Therefore, it is not necessary to execute the Auto-tuning again.
- By setting  $RT$  to "1" or "2", the Auto-tuning operation starts, and at the end of the tuning,  $d$  will be displayed automatically to  $RT$ .
- After the Auto-tuning operation, the controller starts to operate at the automatically set values of  $P$ ,  $\tau$ , and  $d$ .
- A decimal point at the right end of the SV display flashes during Auto-tuning.

There are two codes for  $RT$  :

	Auto-Tuning is cancelled or not performed	Standard type (Auto-tuning at SV)	Low PV type (Auto-tuning at 10%FS below SV)
Setting code ( $RT$ )	0	1	2

The following graphic on the left represent a Standard type ( $Rf=1$ ) and on the right a Low PV type ( $Rf=2$ ):

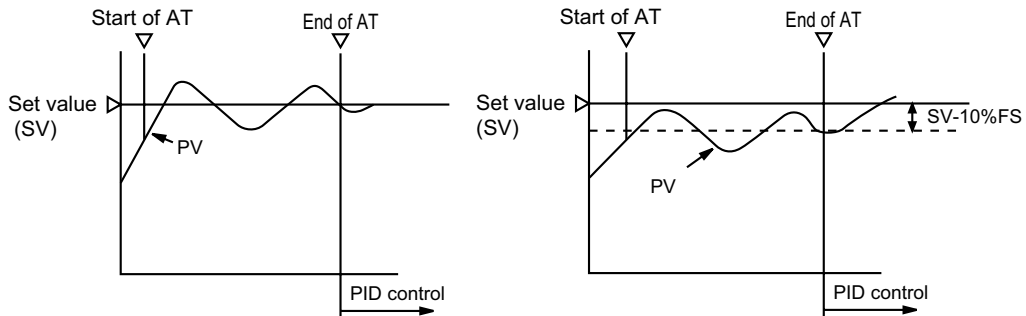

**NOTE:** Since ON/OFF Control is performed during Auto-tuning, overshoot against the SV may occur. To reduce the overshoot, execute the Auto-tuning operation with the Setting code  $Rf=2$  (Low PV) selected.

- The Auto-tuning can be executed both just after power-on and in a control or stable status.
- The PV may be changed greatly depending on the process. So, do not use the Auto-tuning if the process does not allow the significant variation of PV. In addition, the Auto-tuning should not be used in any process such as pressure control and flow control, where a quick-response is required.
- If the Auto-tuning is not completed in four hours, the Auto-tuning is suspected to fail. In this case, check the wiring and parameters such as the control action, input type and etc.

## How to Set the Auto-tuning

The following table presents an example of Setting the Auto-tuning operation to 1:

Step	Action
1	From PV indication $\boxed{1499}$ , press and hold the $\text{SEL}$ key for one second: $5f64$ is displayed.
2	Press the $\blacktriangledown$ key once: $Rf$ is displayed.
3	Press the $\text{SEL}$ key once: $\bar{d}$ is displayed.
4	Press the $\blacktriangle$ or $\blacktriangledown$ to flicker the display and to display $8888!$
5	Press the $\text{SEL}$ key once. $Rf$ is displayed and the Auto-tuning will start. During Auto-tuning, a decimal point at the first digit from the right end of the display flickers. Press and hold the key for one second. Press the $\text{SEL}$ or keys to flicker the display and to display. (Repeat the procedure from 3 to 5 to check the Setpoint value.)
6	When the Auto-tuning finishes properly, a decimal point stops flashing, and the set values of $\bar{P}$ , $\bar{L}$ , and $\bar{d}$ parameters change. When the Auto-tuning finishes abnormally, a decimal point stops flashing, but the set values of $\bar{P}$ , $\bar{L}$ , and $\bar{d}$ parameters remain unchanged.
7	To display the operation status, press and hold the $\text{SEL}$ key for two seconds. The value on the SV displays: $\rightarrow 2500 \leftarrow$ . <b>NOTE:</b> If unoperated state continues, the PV will be displayed: $\boxed{1499}$ .

## Self-Tuning

### Overview

Self-tuning Control is a control which automatically calculates the value of PID, under the condition that the control target or Setpoint value (SV) changes. Self-tuning is especially effective for situations when a high level of control is not needed, but auto-tuning cannot be run due to frequent changes in the control target conditions.

### Description

- At power ON: changing a Setpoint value or the external disturbance, tuning is made automatically so that the PID parameters are re-optimized. It is useful where modification of PID parameters is required repeatable due to frequent change in process condition. If high controllability is important, select the PID or fuzzy control algorithm and use auto-tuning.
- Self-tuning indication:  $\overline{SET}$ . The point indicator at the lower right corner starts blinking until the PID parameters are re-optimized.
- Information
  - Turn on the power of the whole system. The controller should be turned on at the same time with the other equipment or even later. Otherwise, the self-tuning might not be performed successfully.
  - Do not change the SV while the self-tuning is executing.
  - Once PID parameters are optimized, the self-tuning is not executed at the next power on unless SV is changed.
  - After the execution of self-tuning, if the controllability is not your expected level, select PID or FUZZY at  $Ctrl$  parameter, and then, start the auto-tuning.

### Conditions Where Self-Tuning Can be Used

Self-tuning is executed by any of the following conditions:

- During temperature rise at power ON.
- During temperature rise at SV changing if necessary.
- When control is out of stable condition and is judged as being out of stable condition continuously.

### Conditions Where Self-Tuning Cannot be Used

Self-tuning is not executed under the following conditions:

- During standby mode.
- During ON/OFF control.
- During auto-tuning.
- During ramp/soak operation.
- During input error.
- When  $P$ ,  $I$ ,  $d$  or  $RR$  is manually set.

## Conditions to Halt Self-Tuning

Self-tuning is canceled under the following conditions:

- When SV is changed.
- When Self-tuning can not be completed in about 9 hours after the start.

## How to Set the Self-Tuning

The following table presents an example of starting the Control:

Step	Action
1	Turn on the power and set the SV.
2	Select <i>SELF</i> at <i>FFrL</i> (control algorithm) parameter.
3	Turn OFF the power once. <b>NOTE:</b> If the device that is to be controlled has powered ON at this step: wait until the temperature of the device that is to be controlled falls and stabilizes.
4	Turn on the power of the whole system. The controller should be turned on at the same time with the other equipment or even later. Otherwise, the self tuning might not be performed successfully.
5	Self-tuning starts. Then the point indicator at the lower right corner starts blinking until the PID parameters are re-optimized. <b>NOTE:</b> Whenever it is necessary to re-try the self-tuning, please set <i>FFrL</i> = PID once, and then start the above setting procedure from the beginning.

## How to Set the Parameter of *FFrL*

Follow the procedure shown below:

*FFrL* → (SEL) → PID (▼) → FUZY → (▼) → SELF → *FFrL*

The following figure shows the Self-tuning point indicator:

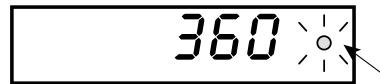

- 1 The point indicator at the lower right corner starts blinking until the PID parameter are re-optimized.

## Alarm Function

### Overview

The Alarm Function is only available with the following 2 references:

- REG24PTP1ALHU
- REG24 PTP1ARHU

*ALM1* Alarm types (Setting range: 0 to 31).

### Kinds of Alarm

The following kind of alarm are available:

- Absolute value alarm.
- Deviation alarm.
- Combination alarm.
- Zone alarm.

### Description

- These parameters are used for selecting the operation types of Alarms 1.
- The display of the parameter in which the alarm value is set varies depending on the alarm operation types.

#### NOTE:

- Since the alarm Setpoint value may change after changing the alarm operation types, be sure to set the alarm Setpoint value again.
- After changing the alarm operation types, power the Controller OFF, and then ON.
- Setting code 0 indicates "No alarm".

The following table presents the alarm Setpoint value and alarm operations:

		Alarm Setpoint value (AL)	
		Plus setting	Minus setting
Absolute value	Upper limit		Disabled
	Lower limit		Disabled
Deviation value	Upper limit		
	Lower limit		

## ON Delay Function

The following table presents the ON delay function:

Item	Delay
Alarm (1)	<p>① ON OFF</p>
Without ON delay function (2)	<p>② ON OFF</p>
With ON delay function (3)	<p>③ ON OFF</p> <p>④</p>
(4): ON delay setting time	

## Energizing / De-energizing function

The following table presents the Energizing/De-energizing function:

Item	Delay
Relay output (5)	<p>⑤ ON OFF</p>
Without De-energizing function (6)	<p>⑥ ON OFF</p>
With De-energizing function (7)	<p>⑦ ON OFF</p>

**NOTE:** When the power is turned OFF or in Standby mode, even if de energizing function is turned ON, it cannot be output (it is kept OFF).

## Alarm function

The following table presents the Alarm function:

No.	Function	Description	Parameter to Set
1	Hysteresis	Set the hysteresis to avoid chattering.	Alarm 1: <i>AlHy</i>
2	ON delay	The alarm is turned on with delay of a certain seconds as previously set after PV goes in the alarm band.	Alarm 1: <i>AlY1</i>
3	Alarm latch	Keeps the alarm ON status once an alarm is turned ON. To cancel the alarm latch, take one of the following procedure:	-
		(1) Turn ON the controller again.	-
		(2) Turn the alarm latch settings to OFF once.	Alarm 1: <i>AlOP</i>
		(3) Use alarm latch cancel parameter.	<i>ALCH</i>
4	Error status alarm	Alarm is turned on when error indications are displayed.	Alarm 1: <i>AlOP</i>
5	De-energizing	Alarm output can be de-energized.	Alarm 1: <i>AlOP</i>

The following table presents the Combination of Alarm function:

Status	Without HOLD/Timer	With HOLD	With Timer-
Alarm latch	+	+	-
De-energizing	+	+	+
ON delay	+	Note	-
Alarm in error status	+	+	-
+ Possible combinaison - Impossible combinaison			

**NOTE:** If HOLD has not been canceled, the HOLD state is canceled as soon as the measured value goes out of alarm band. If HOLD has been canceled, ON delay is activated as soon as the measured value goes into the alarm band.

The following table presents the informations on Alarm:

No.	Informations	Items/Classification
1	Note that the ON delay function is effective for alarm in error status.	Alarm in error status
2	Even during <i>Err</i> display, alarms in error status work.	Alarm at error indication
3	Even when <i>LLLL</i> or <i>UUUU</i> is displayed, an alarm function works normally.	
5	With the HB alarm, ON delay function, de-energizing function and latch function cannot be used.	HB alarm
6	The minimum alarm Setpoint value is -199.9.	Alarm set value
7	As the alarm action type changed, the alarm Setpoint value may also be changed accordingly.	
8	Note that all of alarm outputs are not provided at the standby condition.	Alarm at standby mode
9	Error status alarm is not provided at the standby mode.	
10	The HOLD function is effective even if the PV value is in the hysteresis area when the power is turned ON.	-

### Alarm Action type Code











The following table presents the meaning of symbols used in the following operation figures:

Alarm type	Alarm 1 Display symbol	Alarm 1 Screen name
0...11	AL1	Set value of Alarm 1
16...31	A1-L	Lower-limit of set value of Alarm 1
	A1-H	Upper-limit of set value of Alarm 1

#### NOTE:

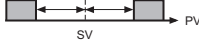
- The display of the parameter in which the alarm value is set varies depending on the alarm operation types.
- Since the alarm set value may change after changing the alarm operation types, confirm the alarm set value.

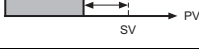
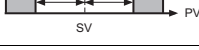
The following table presents the alarm action type codes for standard types:

	ALM1	Alarm type	Operation figure
	0	No alarm	
Absolute value alarm	1	Upper-limit absolute value	
	2	Lower-limit absolute value	
	3	Upper-limit absolute value (with hold)	
	4	Lower-limit absolute value (with hold)	
Deviation value alarm	5	Upper-limit deviation	
	6	Lower-limit deviation	
	7	Upper and lower limits deviation	
	8	Upper-limit deviation (with hold)	
	9	Lower-limit deviation (with hold)	
	10	Upper and lower limits deviation (with hold)	
Range alarm	11	Range upper and lower limits deviation (ALM1 independent operation)	

The following table presents the alarm codes with dual set values:

	ALM1	Alarm type	Operation figure
Upper and lower limits alarm	16	Upper and lower limits absolute value	
	17	Upper and lower limits deviation	
	18	Upper limit absolute value and lower limit deviation	
	19	Upper limit deviation and lower limit absolute value	
	20	Upper and lower limits absolute value (with hold)	
	21	Upper and lower limits deviation (with hold)	
	22	Upper limit absolute value and lower limit deviation (with hold)	
	23	Upper limit deviation and lower limit absolute value (with hold)	

	ALM1	Alarm type	Operation figure
Range alarm	24	Range upper and lower limits absolute value	
	25	Range upper and lower limits deviation	
	26	Range upper limit absolute value and lower limit deviation	
	27	Range upper limit deviation and lower limit absolute value	
	28	Range upper and lower limits absolute value (with hold)	
	29	Range upper and lower limits deviation (with hold)	
	30	Range upper limit absolute value and lower limit deviation (with hold)	
	31	Range upper limit deviation and lower limit absolute value (with hold)	

**dLYn** Delay time of Alarm 1

**ALn** Set value of Alarm 1

**PV** Process Value

**SV** Setpoint Value

## How to Cancel Alarm Latch

*LALH*, Canceling the Alarm Latch (Setting range: 0/1).

The following table presents an example of canceling the alarm latch:

Step	Action
1	From PV indication <span style="border: 1px solid black; padding: 2px;">1499</span> press and hold the <span style="border: 1px solid black; border-radius: 50%; padding: 2px;">SEL</span> key for one second: <span style="border: 1px solid black; padding: 2px;">5f64</span> is displayed.
2	Press the <span style="border: 1px solid black; border-radius: 50%; padding: 2px;">▼</span> key once: <i>LALH</i> is displayed.
3	Press the <span style="border: 1px solid black; border-radius: 50%; padding: 2px;">▲</span> or <span style="border: 1px solid black; border-radius: 50%; padding: 2px;">▼</span> to flicker and to display: <i>!</i> .
4	Press the <span style="border: 1px solid black; border-radius: 50%; padding: 2px;">SEL</span> key once. The state for control is selected (control output and all the alarm outputs: OFF). <b>NOTE:</b> Repeat the steps 2 to 4 to check the Setpoint value.
5	To display the operation status, press and hold the <span style="border: 1px solid black; border-radius: 50%; padding: 2px;">SEL</span> key for two seconds. The value on the SV display will flash, indicating the standby status: <span style="border: 1px solid black; padding: 2px;">5f64</span> . <b>NOTE:</b> If unoperated state continues, the PV will be displayed: <span style="border: 1px solid black; padding: 2px;">5f64</span> .

## Ramp/Soak

### Overview

The Ramp/Soak function changes the Setpoint value (SV) as the time elapses, in accordance with a predetermined program pattern.

### Description

- Either 4 Ramp/Soak x 2 patterns or 8 Ramp/Soak x 1 patterns can be programmed.
- The first ramps starts from the Process Value (PV) just before the program is executed. It is also possible to run the program automatically.

The graphics below show the performance of the Ramp/Soak function:

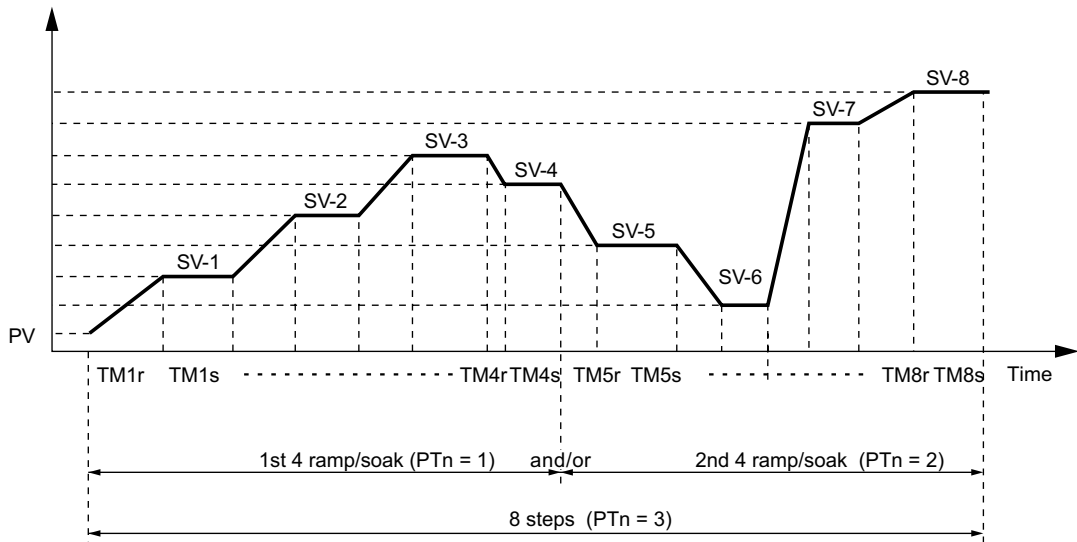

## Ramp/Soak Patterns

The table below shows the Ramp/Soak patterns:

PTn	Pattern	Ramp/Soak
1	1	4
2	2	4
3	1+2	8

- Select the program pattern (PTn) and set the rUn at "ProG" parameter.
- While Ramp/Soak program is running, Ramp/Soak pattern can not be changed.

**NOTE:** If the controller switches to stand by mode, the Ramp/Soak program is canceled. As a consequence, if the controller switches back to operation mode, the program doesn't run again.

## Starting the Ramp/Soak Operation

The following table presents an example of starting the Ramp/Soak operation:

Step	Action
1	From PV indication $\boxed{1499}$ , press and hold the $\boxed{\text{SEL}}$ key for one second; $\boxed{5764}$ is displayed.
2	Press the $\blacktriangledown$ key to display $\boxed{\text{PrG}}$ .
3	Press the $\boxed{\text{SEL}}$ key once. The current setting $\boxed{0FF}$ is displayed.
4	Press the $\blacktriangle$ or $\blacktriangledown$ keys, the display flickers and $\boxed{\text{rUn}}$ is displayed.
5	Press the $\boxed{\text{SEL}}$ key once. Then the program will start according to the Ramp/Soak pattern that is set in advance. <sup>1</sup>
6	To display the operation status, press and hold the $\boxed{1499}$ key for two seconds. <b>NOTE:</b> If unoperated state continues, the PV will be displayed.

<sup>1</sup> When the program was not set, it is turned to *End*.

## Ramp/Soak Mode Setting Range 0 to 15

The following table shows the items that can be set:

Power On Start	Ramp/Soak Starts running from the current PV
Ending Output	Show the ending output during OFF after Ramp/Soak has been completed.
OFF Output	Show the output during OFF after Ramp/Soak has been completed.
Repeat Operation	After finishing the last step in Ramp/Soak, the process starts again from first step.

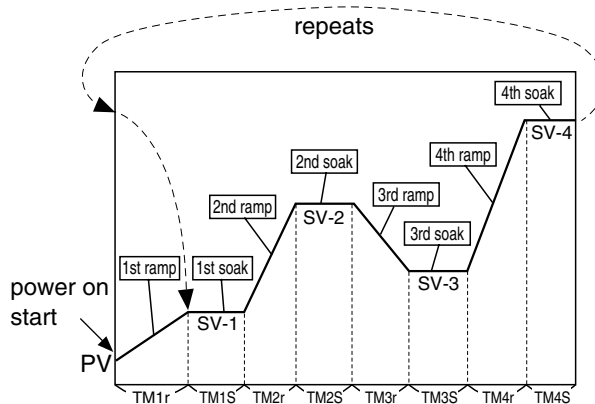

You can choose from the following 16 types of modes according to the combination of run method options:

Setting	Power On Start	Ending Output	OFF Output	Repeat Operation
0 9999	Off	Continuous control	Continuous control	Off
1 9999	Off	Continuous control	Continuous control	On
2 9999	Off	Continuous control	Standby mode	Off
3 9999	Off	Continuous control	Standby mode	On
4 9999	Off	Standby mode	Continuous control	Off
5 9999	Off	Standby mode	Continuous control	On
6 9999	Off	Standby mode	Standby mode	Off

Setting	Power On Start	Ending Output	OFF Output	Repeat Operation
7888	Off	Standby mode	Standby mode	On
8888	On	Continuous control	Continuous control	Off
9888	On	Continuous control	Continuous control	On
1088	On	Continuous control	Standby mode	Off
1188	On	Continuous control	Standby mode	On
1288	On	Standby mode	Continuous control	Off
1388	On	Standby mode	Continuous control	On
1488	On	Standby mode	Standby mode	Off
1588	On	Standby mode	Standby mode	On

## Other Function: Anti-reset windup (Ar) and Output Convergence Value (bAL)

### Overview

The parameters  $bAL$  and  $Ar$  are masked at default setting.

- $bAL$  and  $Ar$  are used to suppress overshoot.
- $Ar$  (Anti-reset wind-up) is automatically set by Auto-tuning.

**NOTE:** The control routine may not operate properly if the parameter are not correctly defined.

### Output Convergence Value (bAL)

MV is calculated by adding the offset ( $bAL$ ) to  $MV'$ , the result of PID calculation, from PV and SV.

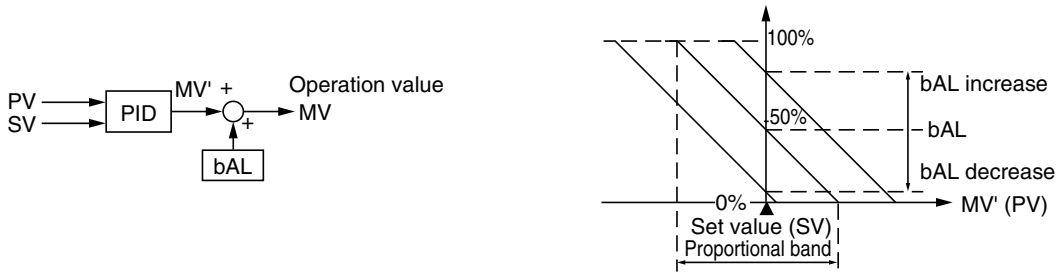

### Anti-reset windup (Ar)

The integral range is  $SV \pm Ar$ . When PV is out of range, the Integral action does not work.

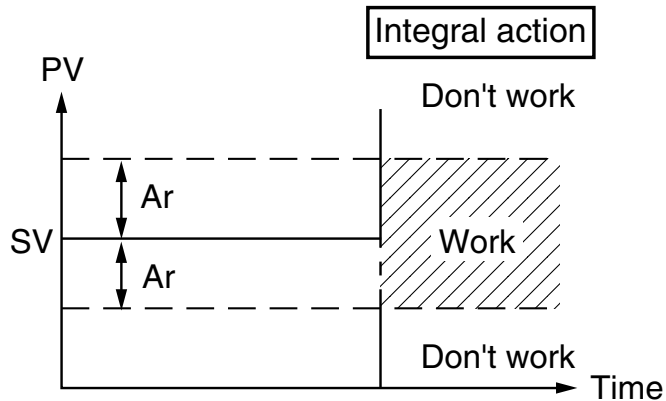



---

## Appendices





# REG24 Error Message

# 5

## Error Indications

### Display During Equipment Error

This controller has a display function to indicate several types of error code shown below. If any of the error code is displayed, please eliminate the cause of error immediately. After the cause is eliminated, turn off the power once, and then re-start the controller:

Display	Possible cause	Control output
<i>UUUU</i>	<ul style="list-style-type: none"> <li>● Thermocouple burnout.</li> <li>● Resistance bulb sensor (A) burnout.</li> <li>● PV exceeds upper limit of the range by 5%FS.</li> </ul>	<ul style="list-style-type: none"> <li>● When the burn-out control output is set as the lower limit: OFF or 4mA or less</li> <li>● When the burn-out control output is set as the upper limit: ON or 20mA or more</li> </ul>
<i>LLLL</i>	<ul style="list-style-type: none"> <li>● Resistance bulb sensor B or C wire burnout.</li> <li>● Resistance bulb sensor (between A &amp; B or A &amp; C) short.</li> <li>● PV is below limit of <math>P-5L</math> by 5%FS</li> <li>● Burnout or short in the current/voltage input.</li> </ul>	
<i>LLLL</i>	<ul style="list-style-type: none"> <li>● PV &lt; -199.9</li> </ul>	Control is continued until the value reaches -5%FS or less, after which burn-out condition will occur.
<i>Err</i> (SV flickers)	incorrect range setting ( $P-5L/P-5U$ ).	OFF or 4mA or less
<i>FRLL</i>	fault in the control.	Undefined (Stop using this controller immediately.)



---

# Index

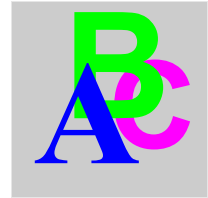

---

## A

Alarm Function of REG24, *55*  
Auto-tuning (AT) of REG24, *50*

## B

Basic Operations of REG24, *33*

## C

Configuration of REG24, *31*

## D

Dimensions and installation of REG24, *20*  
Display and Controller References of  
REG24, *12*

## E

Electrical Characteristics of REG24, *18*  
Environmental Characteristics of REG24, *19*

## H

How to Configure REG24by Front Panel, *32*

## K

Key Lock, *35*

## M

Main Characteristics of REG24, *15*

## O

ON/OFF Control of REG24, *48*

## P

Parameters List of REG24, *41*

## R

Ramp/Soak of REG24, *63*

## S

Self-Tuning of REG24, *53*  
Setting the Temperature Controller, *37*

## W

Wiring of REG24, *27*

