

DIMENSIONAL DETAILS

REFERENCE NUMBER	NUMBER OF POLES	DIMENSIONS			
		A	B	C	D
SAU40012183DF	12	296.5	194	54	108
SAU40018183DF	18	350.5	248	108	162
SAU40024183DF	24	404.5	302	162	216
SAU40030183DF	30	458.5	356	216	270
SAU40036183DF	36	512.5	410	270	324
SAU40042183DF	42	566.5	464	324	378
SAU40048183DF	48	620.5	518	378	432
SAU40060183DF	60	728.5	626	486	540
SAU40072183DF	72	836.5	734	594	648
SAU40084183DF	84	944.5	842	702	756
SAU40096183DF	96	1052.5	950	810	864
SAU400108183DF	108	1160.5	1058	918	972

- NOTE**
- BALLOONED DIMENSIONS ARE CRITICAL & SUBJECT TO PART CAPABILITY.
 - BALLOONED NOTES ARE FOR GAUGING & PPEP REQUIREMENTS.
 - OTHER DIMENSIONS ARE MAJOR AND SUBJECT TO METROLOGY CONFIRMATION.
 - DIMENSIONS NOT SHOWN REFER TO THE 3D MODEL WITH A TOLERANCE OF ±0.2mm.
 - RADII & DRAFT AS PER 3D MODEL.
 - ENGRAVING DETAIL AS PER 3D MODEL UNLESS OTHERWISE SPECIFIED.
 - ALL DIMENSIONS ARE COMPONENT.
 - 24 POLE VERSION (SAU40024183DF) SHOWN.
 - ALL UNITS ARE STANDARD TF UNLESS SPECIFIED BY "DF" OR "BF" AT END OF PART NUMBER.

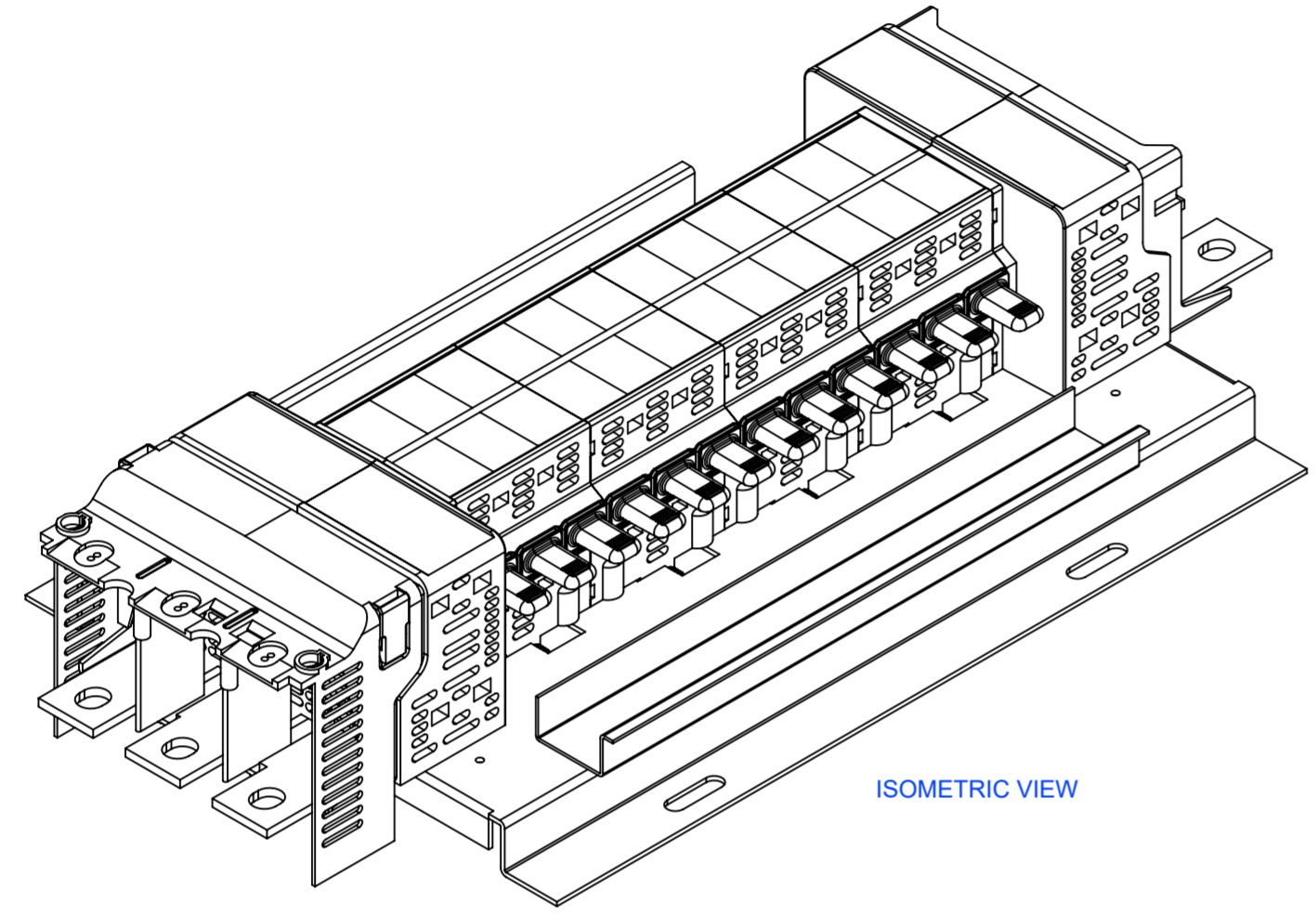

ISOMETRIC VIEW

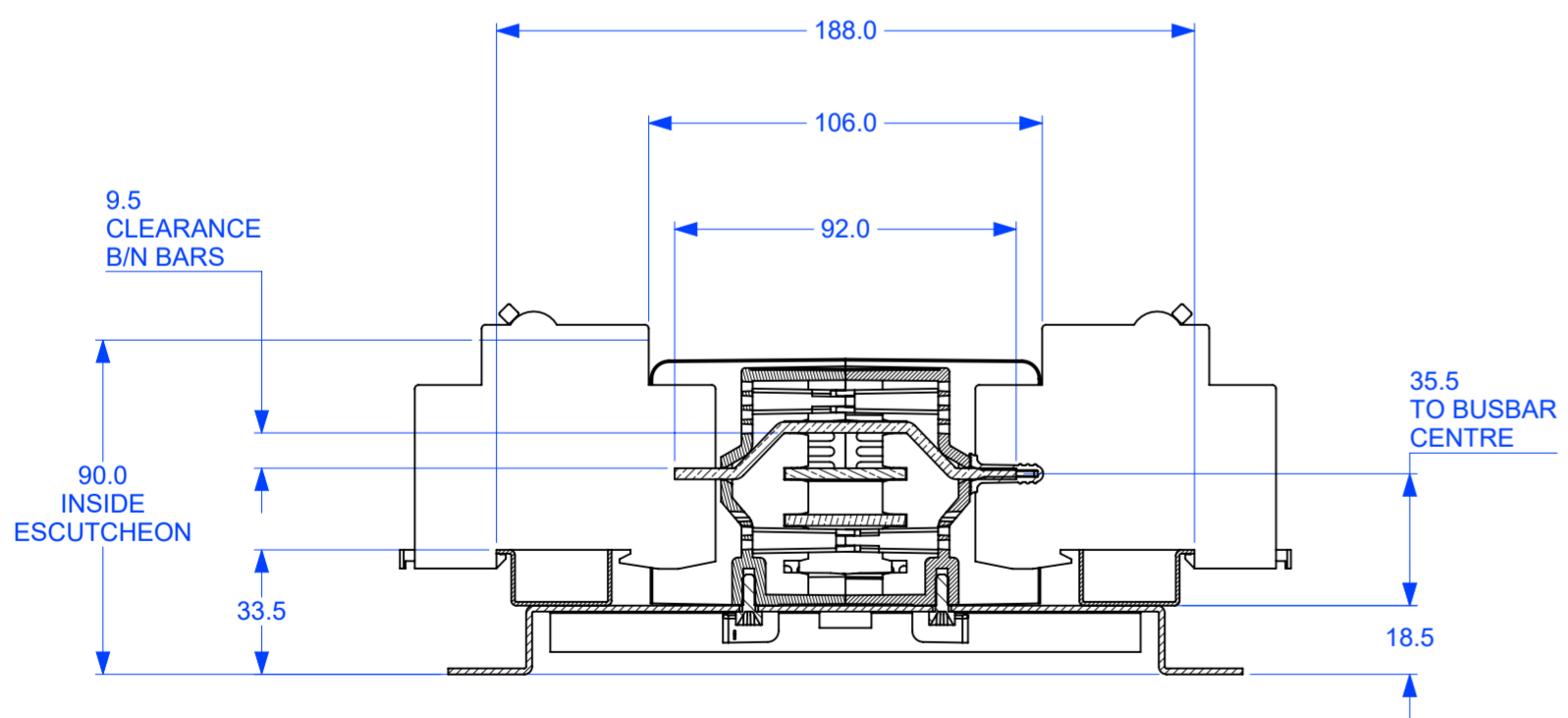
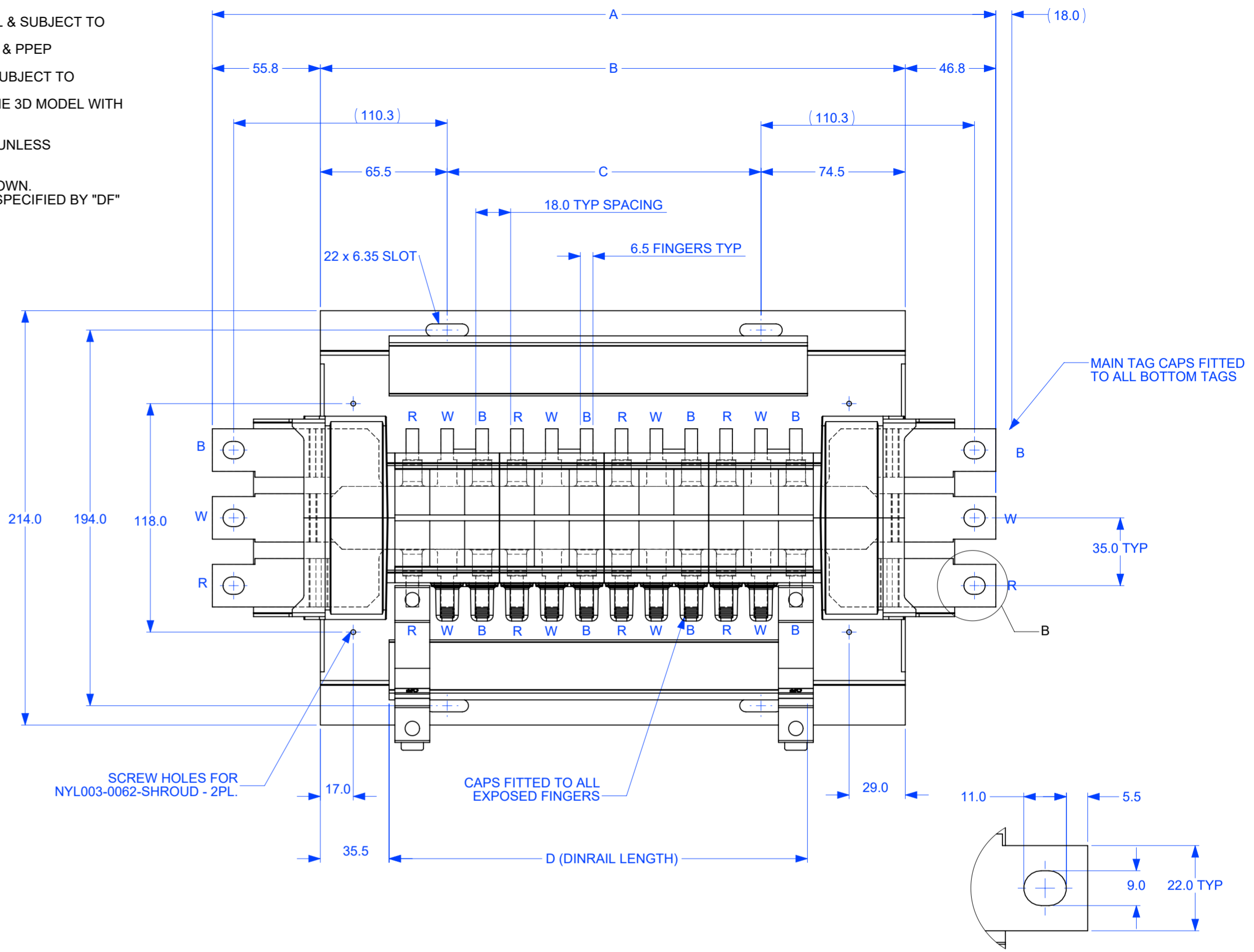

SECTION A-A

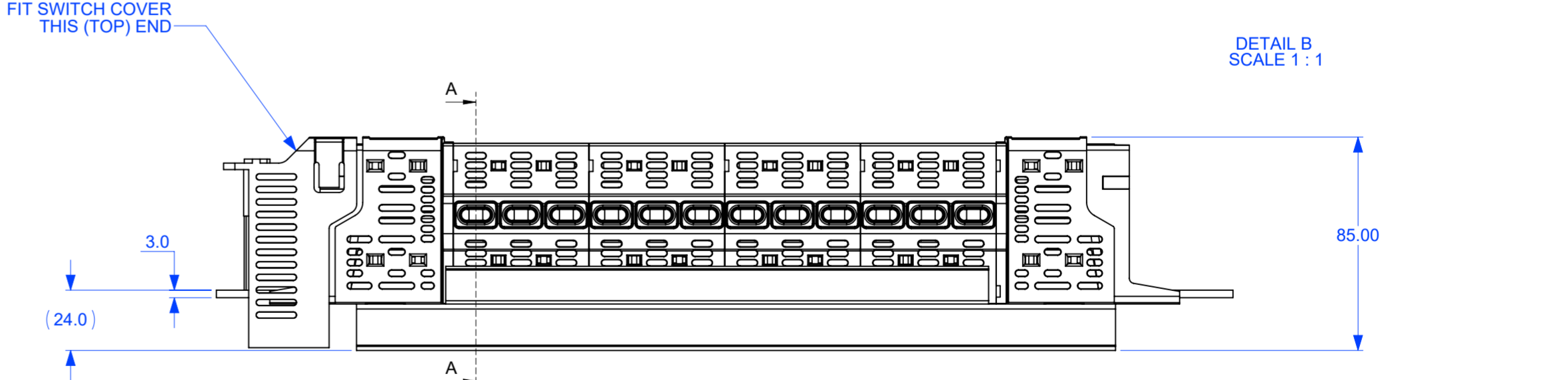

REV	DATE	REVISION DETAILS
D	29/03/2022	3/4 RAIL IMPLEMENTED
C	23/05/2016	- PAN MOVED UP BY 2mm TO MATCH SAMPLES. - DIMENSION 55.75 WAS 57.75 (A8). - DIMENSION 110.25 ADDED (B5). - SLOT LENGTH INCREASED TO 22.00 (WAS 12.7) (B8). - SCREW HOLES ADDED FOR NYL003-0062-SHROUD (E8).
B	8/12/2015	- DIM "B" REDUCED BY 6mm. - DIM "D" REDUCED BY 2mm.

PART	MATERIAL	FINISH
BUSBARS	3.00 COPPER C110 1/2 HARD	
MOUNTING PAN	1.2mm ZINC SEAL AS1397/G2S	PEARL WHITE POWDERCOAT AS4506 CLASS C1
MOUNTING RAIL	1.0mm ZINC SEAL AS1397/G2S	

GENERAL TOLERANCES		MATERIAL	
NOMINAL DIM. RANGE (mm)	TOLERANCE	COLOUR	FINISH
OVER	UP TO	SEE TABLE	SEE TABLE
0.5	3		
3	6		
6	30		
30	120		
120	400		
400	1000		
ANGULAR			
	±1°		
DO NOT SCALE	PROJECTION		
DIMENSIONS IN MILLIMETRES UNLESS OTHERWISE STATED			

Schneider Electric SCHNEIDER ELECTRIC PTY LTD
 73 WATERLOO ROAD, MACQUARIE PARK NSW, 2113, AUSTRALIA. ABN 42 004 969 304

DESCRIPTION: SAU CHASSIS - STANDARD 400A 18mm - DF
 DWG. NO: SAU400XX183DF
 3D FILE NAME: SAU40024183DF.SLDASM

SCALE: 1:2
 SIZE: A2
 SHEET: 1 OF 1

© COPYRIGHT THIS DRAWING IS ISSUED BY SCHNEIDER ELECTRIC PTY LTD ON THE UNDERSTANDING THAT IT IS STRICTLY CONFIDENTIAL AND MAY NOT BE REPRODUCED OR UTILIZED IN ANY WAY WITHOUT PRIOR PERMISSION.