

DIMENSIONAL DETAILS

REFERENCE NUMBER	NUMBER OF POLES	DIMENSIONS			
		A	B	C	D
SAU40012273	12	256	198	108	162
SAU40018273	18	337	279	189	243
SAU40024273	24	418	360	270	324
SAU40030273	30	499	441	351	405
SAU40036273	36	580	522	432	486
SAU40042273	42	661	603	513	567
SAU40048273	48	742	684	594	648
SAU40060273	60	904	846	756	810
SAU40072273	72	1066	1008	918	972
SAU40084273	84	1228	1170	1080	1134
SAU40096273	96	1390	1332	1242	1296

NOTE

1. BALLOONED DIMENSIONS ARE CRITICAL & SUBJECT TO PART CAPABILITY.
2. BALLOONED NOTES ARE FOR GAUGING & PPEP REQUIREMENTS.
3. OTHER DIMENSIONS ARE MAJOR AND SUBJECT TO METROLOGY CONFIRMATION.
4. DIMENSIONS NOT SHOWN REFER TO THE 3D MODEL WITH A TOLERANCE OF ±0.2mm.
5. RADII & DRAFT AS PER 3D MODEL.
6. ENGRAVING DETAIL AS PER 3D MODEL UNLESS OTHERWISE SPECIFIED.
7. ALL DIMENSIONS ARE COMPONENT.
8. 18 POLE VERSION (SAU40018273) SHOWN.
9. ALL UNITS ARE STANDARD TF UNLESS SPECIFIED BY "DF" OR "BF" AT END OF PART NUMBER.

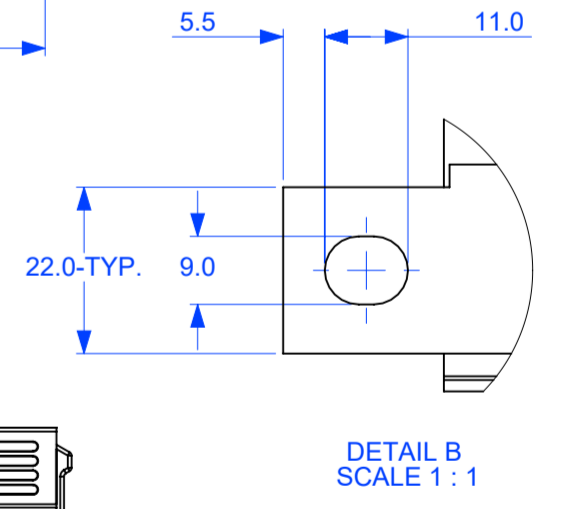
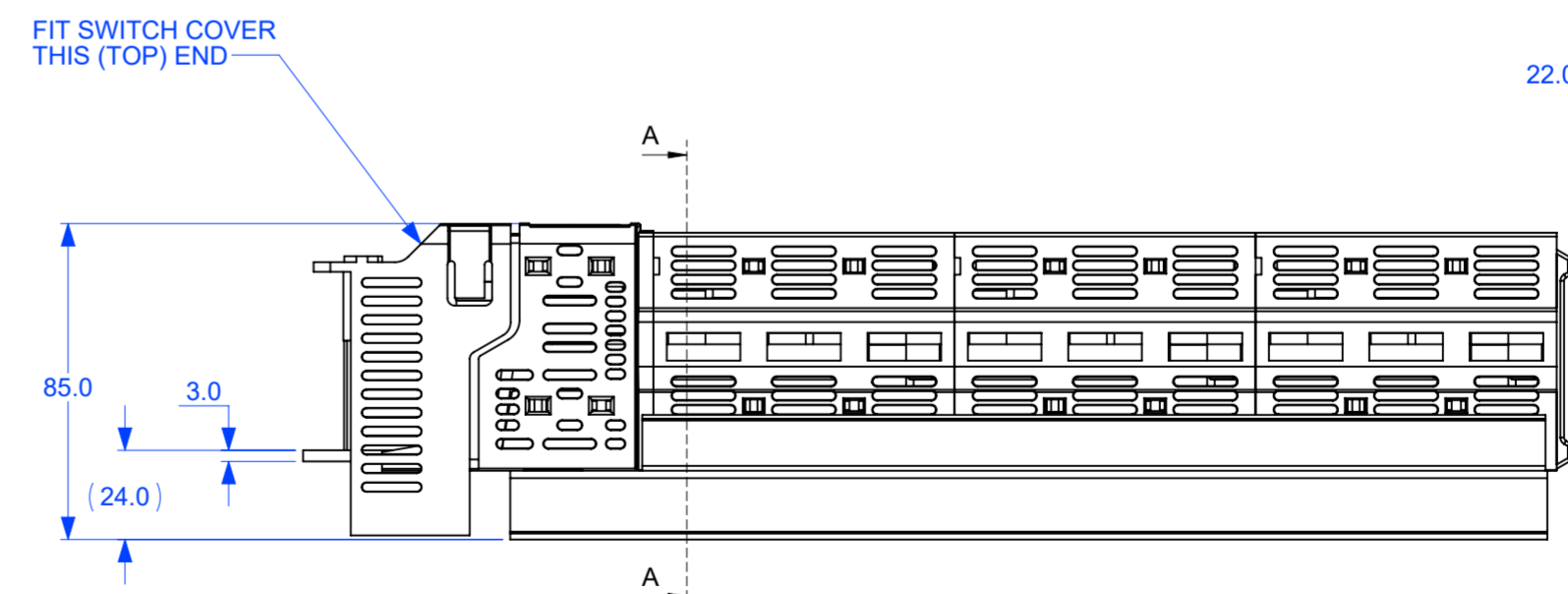
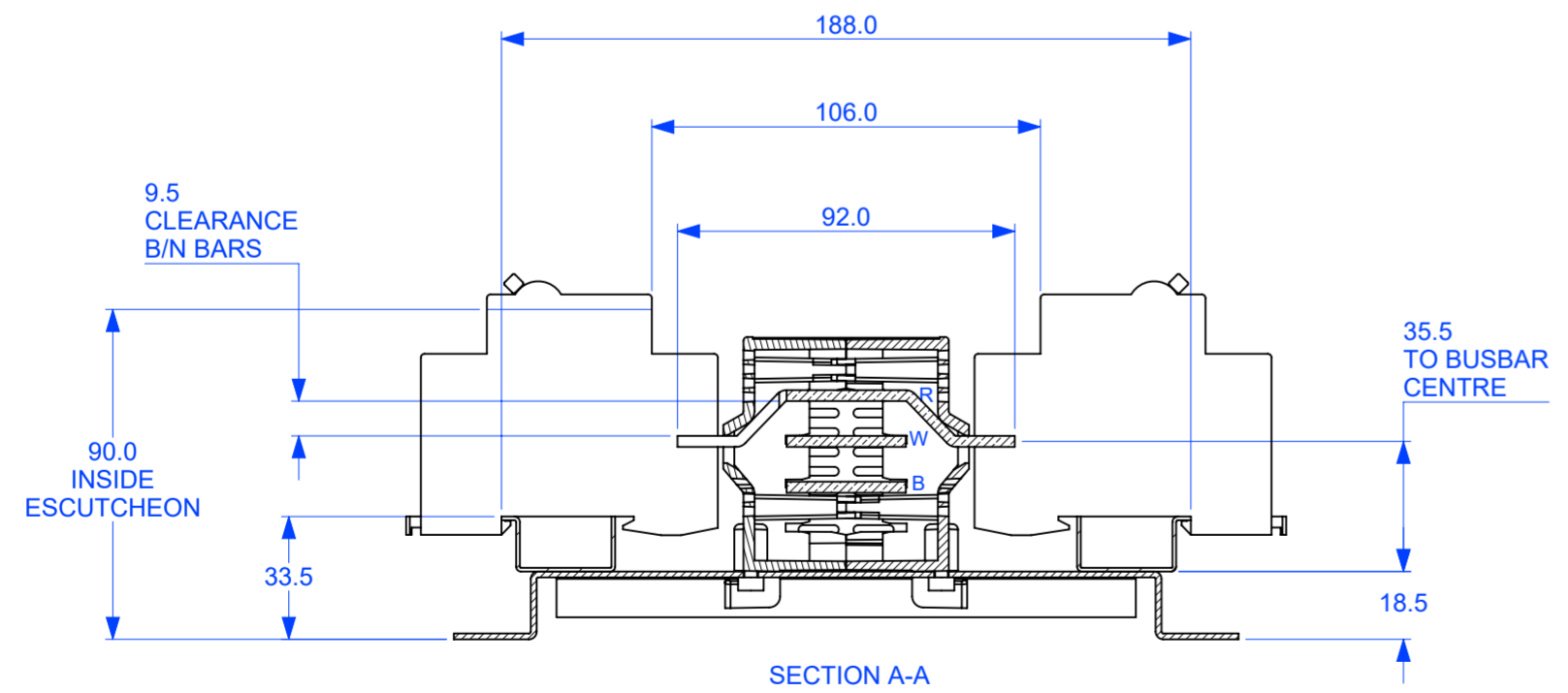
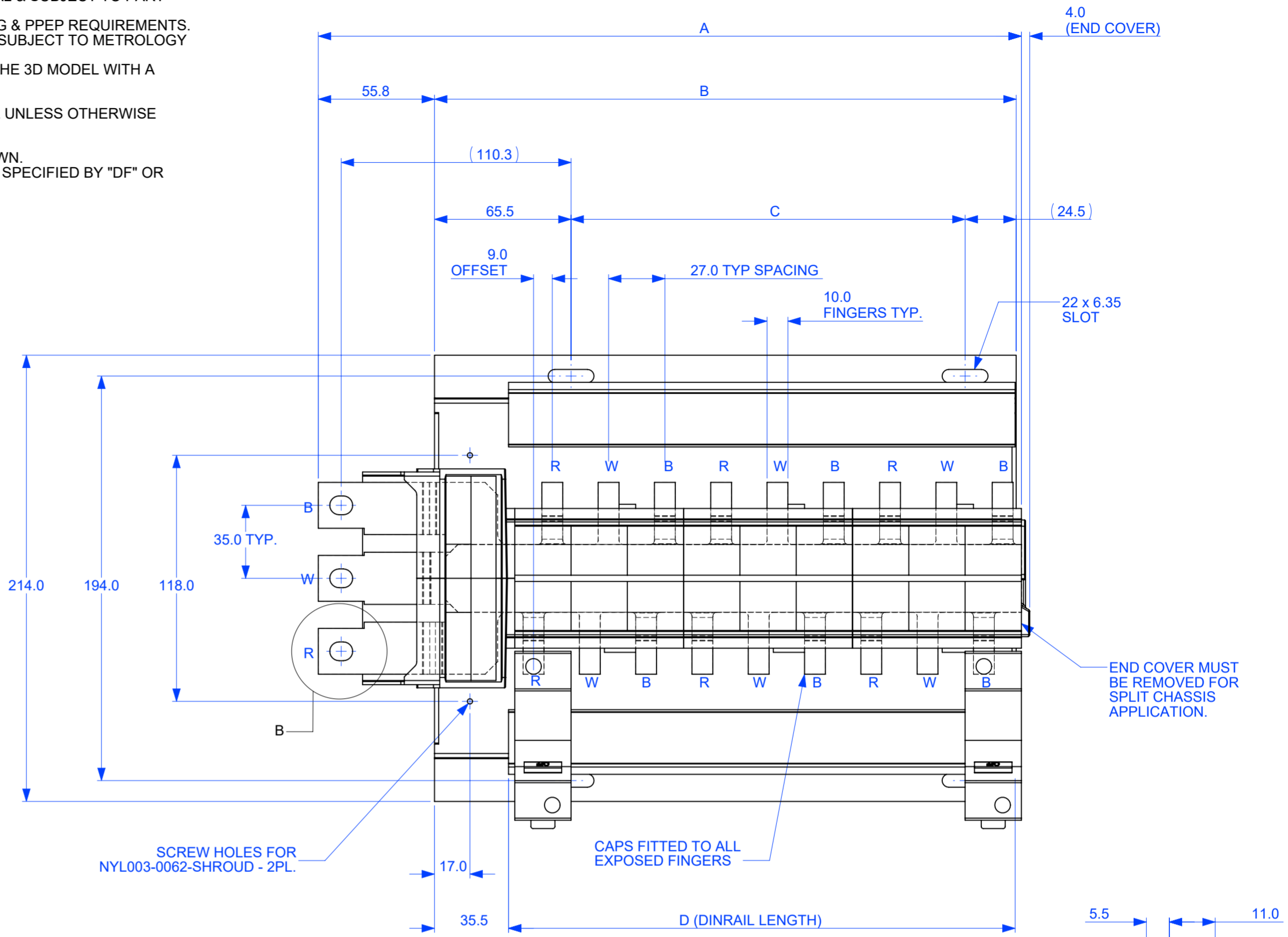
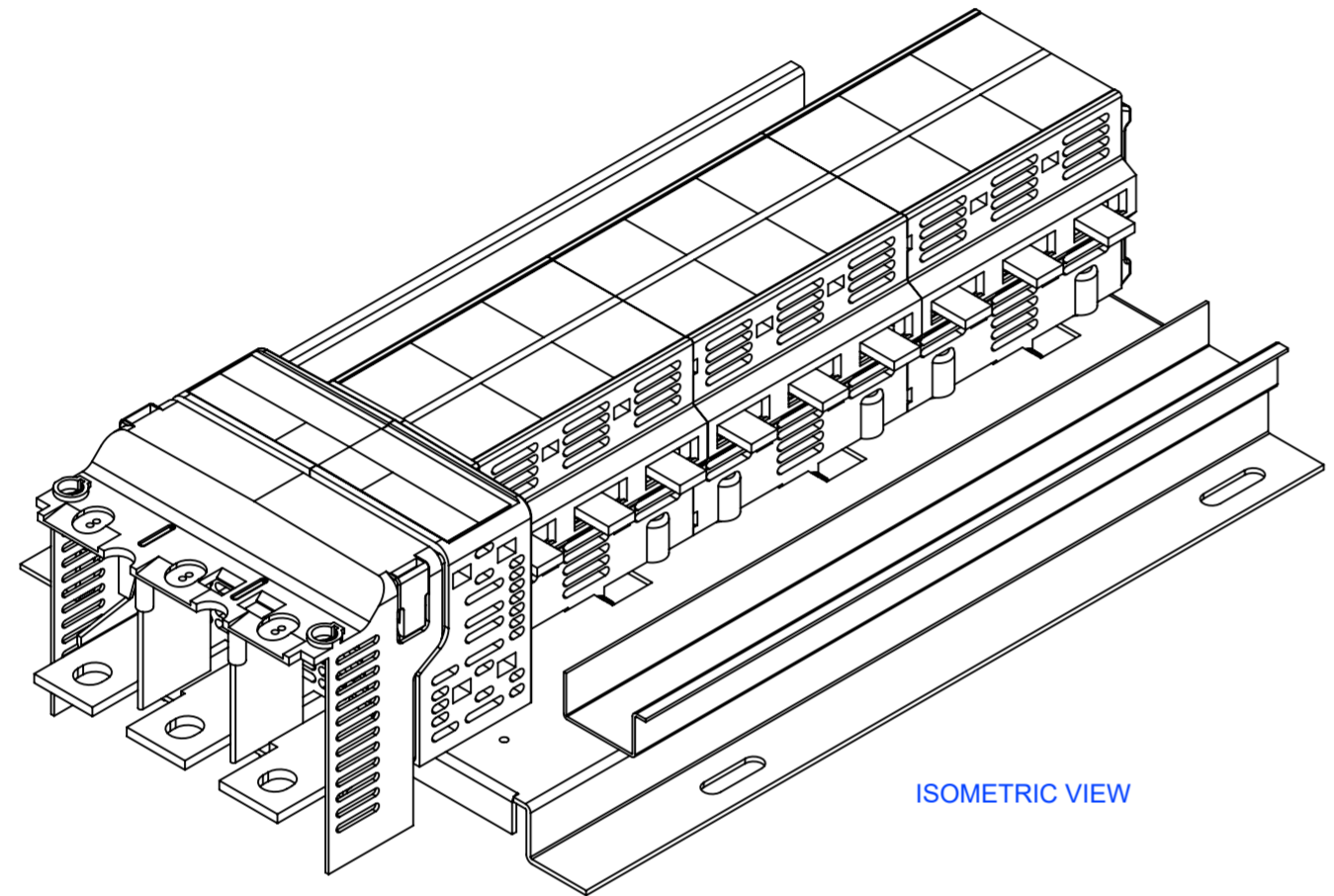

PART	MATERIAL	FINISH
BUSBARS	3.00 COPPER C110 1/2 HARD	
MOUNTING PAN	1.2mm ZINC SEAL AS1397/G2S	PEARL WHITE POWDERCOAT AS4506 CLASS C1
MOUNTING RAIL	1.0mm ZINC SEAL AS1397/G2S	

GENERAL TOLERANCES		MATERIAL	
NOMINAL DIM. RANGE (mm)	TOLERANCE	COLOUR	SEE TABLE
OVER	UP TO	FINISH	SEE TABLE
0.5	3	MODELLED	AW WDG
3	6	DRAWN	AW WDG 29/03/2022
6	30	CHECKED	
30	120	ANGULAR	±1°
120	400	DO NOT SCALE	PROJECTION
400	1000		

Schneider Electric SCHNEIDER ELECTRIC PTY LTD
 73 WATERLOO ROAD, MACQUARIE PARK NSW, 2113, AUSTRALIA. ABN 42 004 969 304

DESCRIPTION: SAU CHASSIS - 400A STANDARD 125 27mm - TF
 DWG. NO. SAU400XX273 SCALE 1:2
 3D FILE NAME SAU25018273.SLDASM SIZE A2 SHEET 1 OF 1

© COPYRIGHT THIS DRAWING IS ISSUED BY SCHNEIDER ELECTRIC PTY LTD ON THE UNDERSTANDING THAT IT IS STRICTLY CONFIDENTIAL AND MAY NOT BE REPRODUCED OR UTILIZED IN ANY WAY WITHOUT PRIOR PERMISSION.

REV	DATE	REVISION DETAILS
A	29/03/2022	FIRST RELEASE